

Dessin/Drawing 251-1

tuyau flexible / flexible pipe
D intérieur / internal D : 20mm

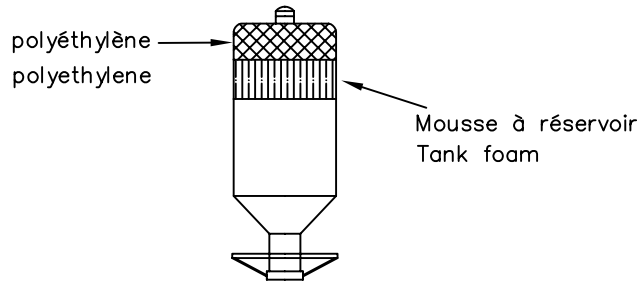
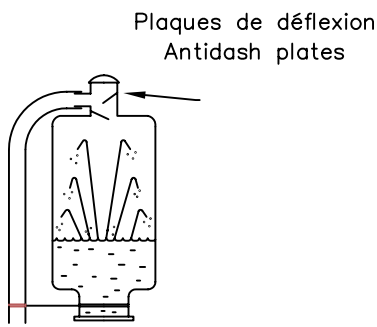

Dessin/Drawing 252-1

Dessin/Drawing 252-2

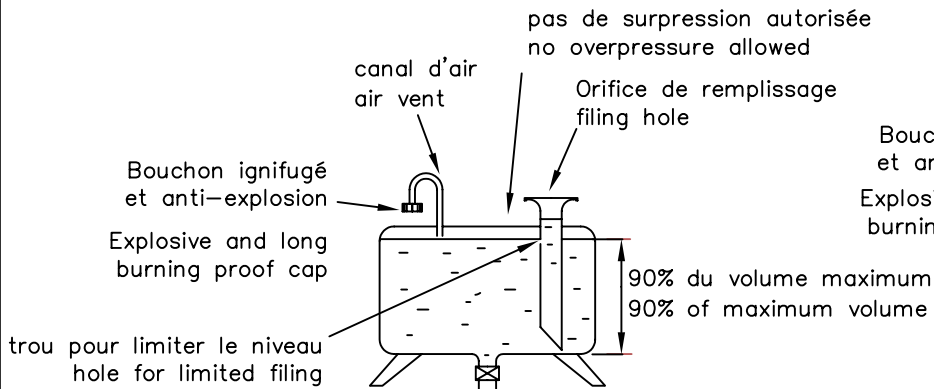

Dessin/Drawing 252-3

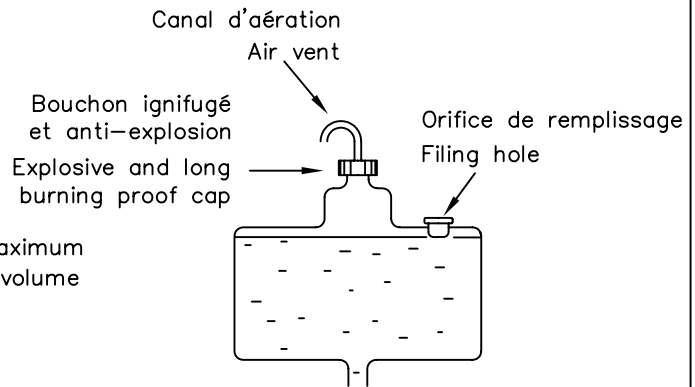

Dessin/Drawing 252-4

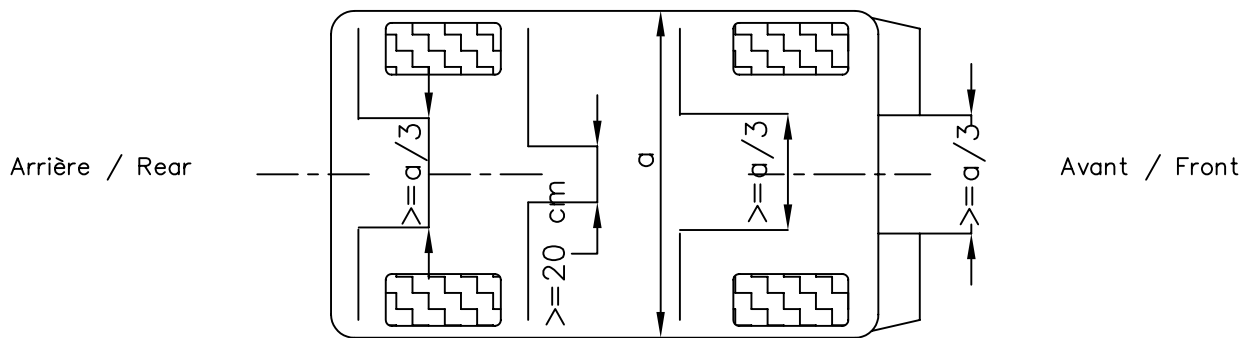

Dessin/Drawing 252-6

	D1	D2	D3	D4	L1
PP20M	2.0"	2.5"	2.25"	3.7"	6.3"
PP20MR	1.5"	2.5"	1.75"	3.7"	6.3"
PF20MS	1.5"	2.5"		3.7"	6.9"
PP15M	1.5"	2.0"	1.75"	3.3"	5.7"
PF30M	1.25"	1.65"	1.45"	2.68"	4.64"
PF40M	1.25"	1.65"	1.45"	2.68"	4.64"
PP125M	1.25"	1.75"	1.5"	2.9"	5.1"

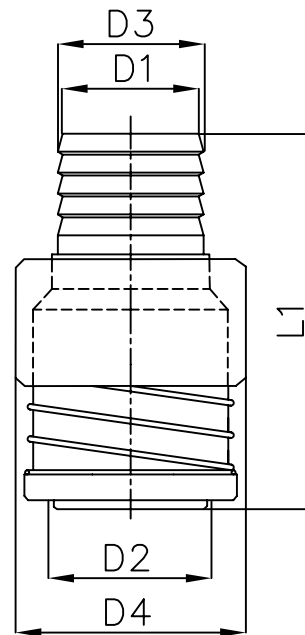

Prise male / Push pull series male

	D1	D2	L3	L4
PP20F	2.0"	2.5"	6.75"	3.25"
PP20FR	2.0"	2.5"	6.75"	3.25"
PF31F	1.75"	2.12"	5.3"	3"
PF41F	1.75"	2.12"	5.7"	3.38"
PP15F	1.5"	2.0"	6.75"	3.25"
PP125F	1.25"	1.75"	6.25"	3.1"

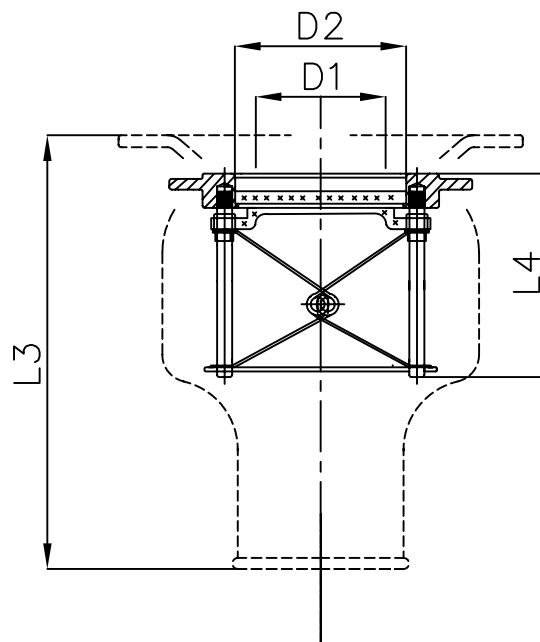

Prise femelle / Push pull series female

Dessin/Drawing 252-5 version A

Montage sur carrosserie
Mounting on bodywork

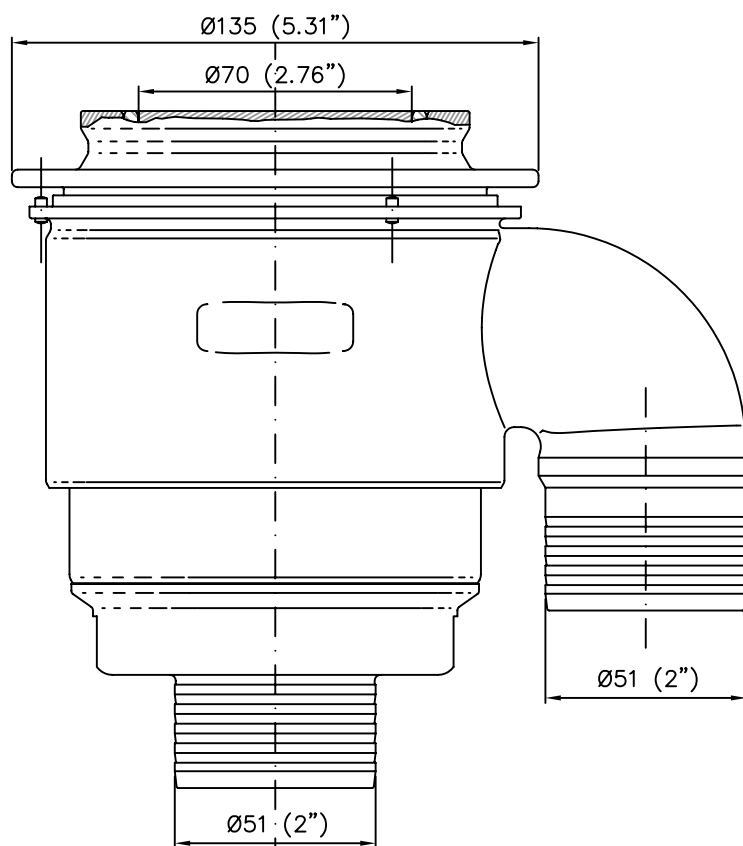

Montage sur réservoir
Mounting on tank

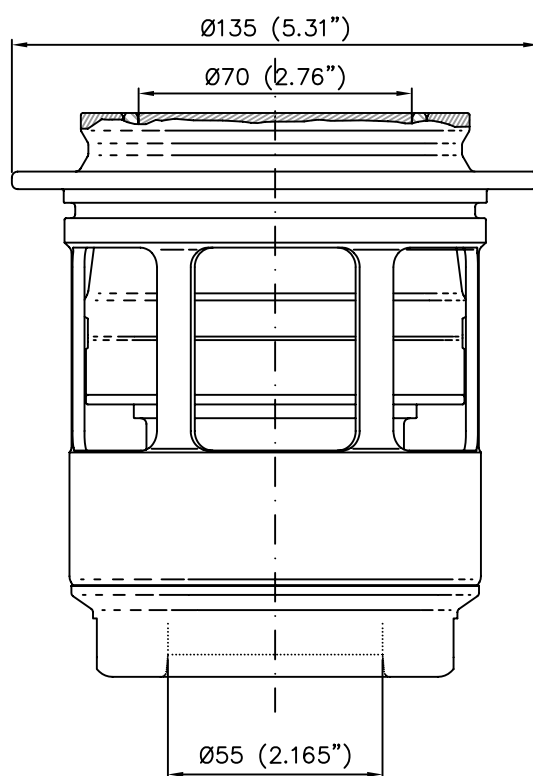

Dessin/Drawing 252-5 version B
Accoupleur femelle / Female coupling

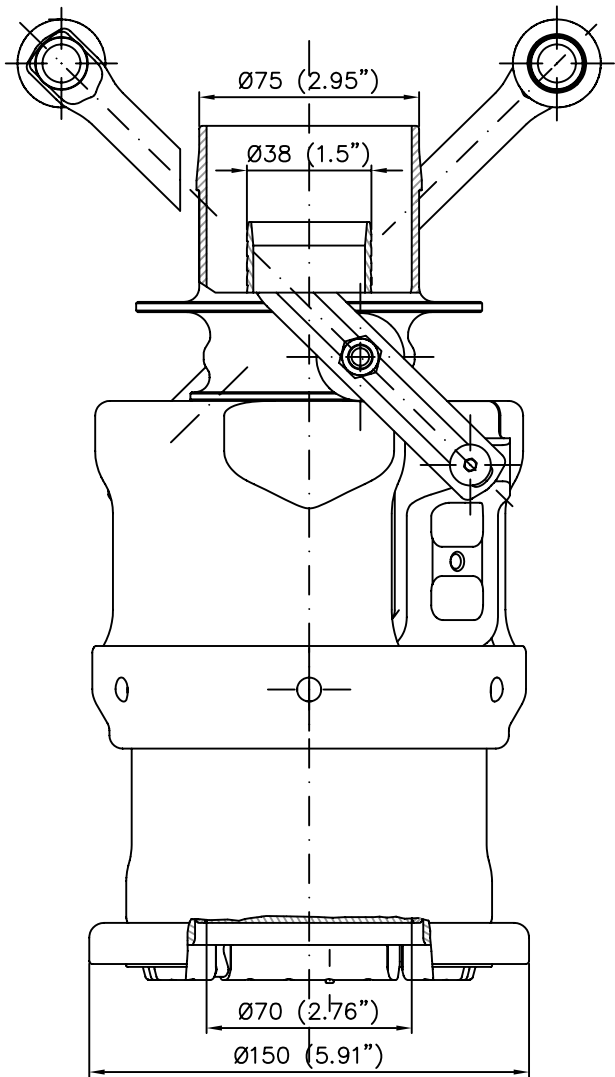

Coaxial

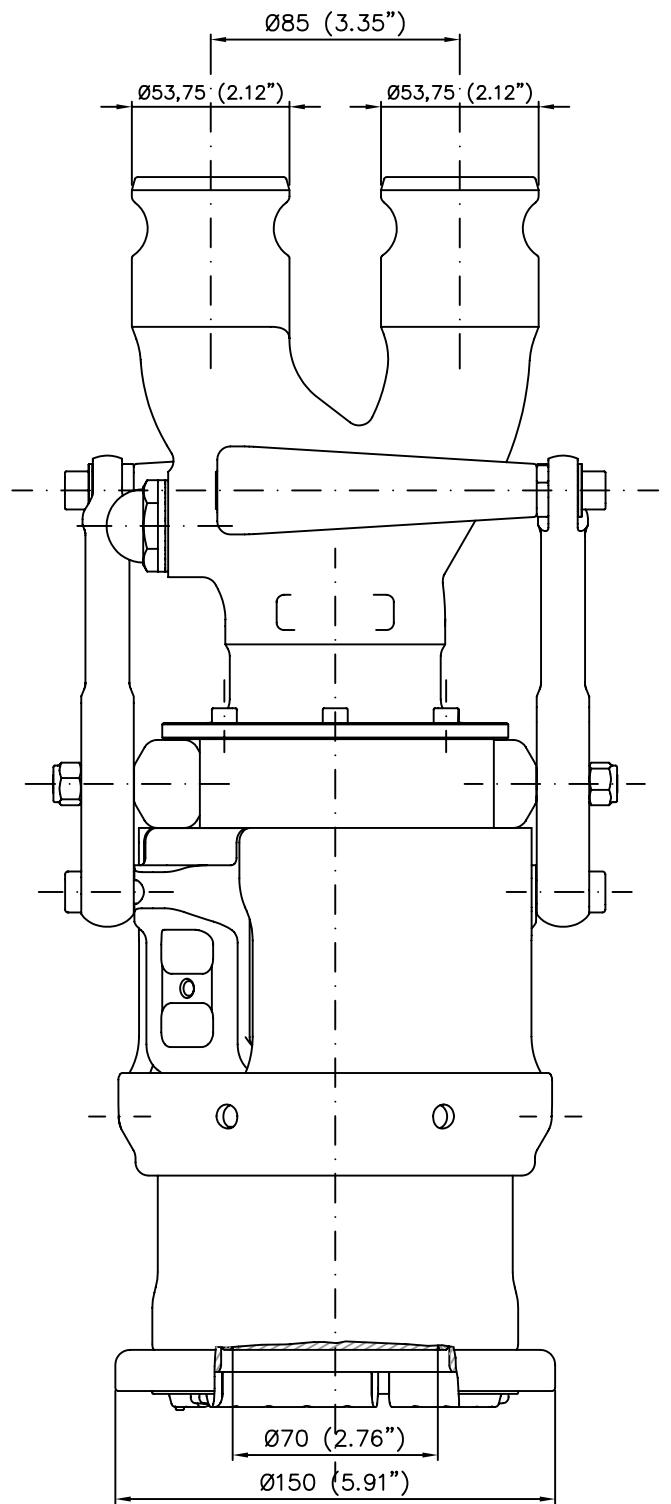

Parallèle / Parallel

Dessin/ Drawing 252-5 version B

Accoupleur mâle / Male coupling

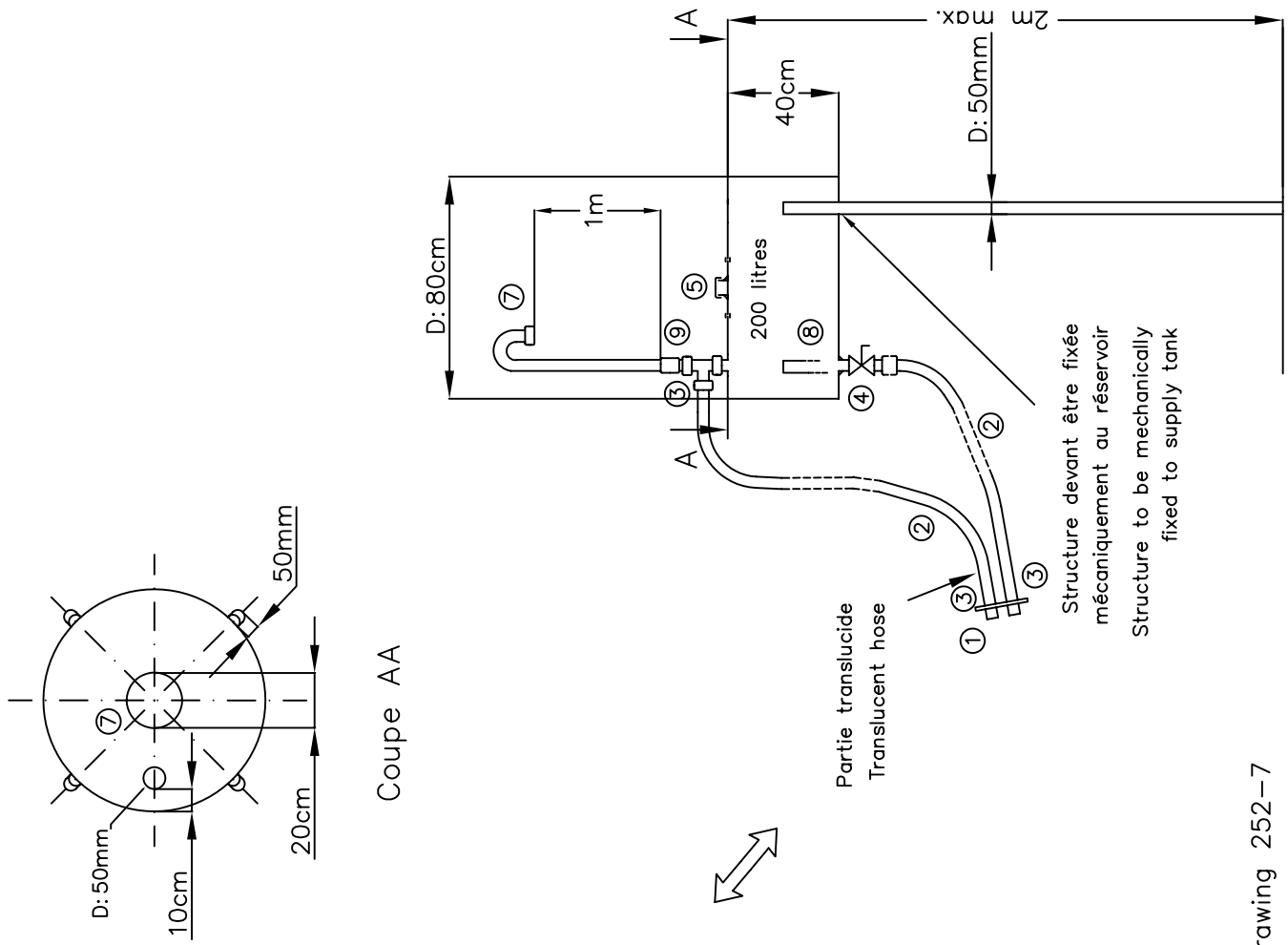

Coupe AA

Partie translucide
Translucent hose

Structure devant être fixée
mécaniquement au réservoir
Structure to be mechanically
fixed to supply tank

- ① Accoupleurs / Male refuelling valves (dessin / drawing 252-5)
- ② Flexible de diamètre intérieur / Hose internal diameter 38mm
- ③ Raccord rapide, diamètre intérieur / Quick coupling, internal diameter 38mm
- ④ Vanne autobloquante de diamètre intérieur / Self closing valve, internal diameter 38mm
- ⑤ Orifice de remplissage (autobloquant) / Filler (dry break)
- ⑦ Arête flamme / Flame arrestor
- ⑧ Resitricteur / Flow restrictor (dessin / drawing 258-3)
- ⑨ Valve de séparation / Discriminator valve

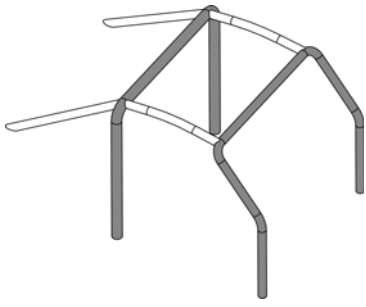

Dessin/Drawing 253-1

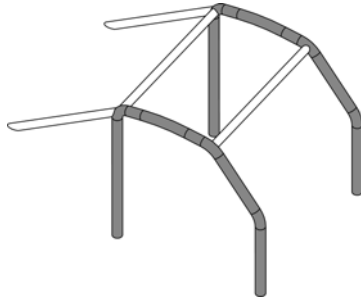

Dessin/Drawing 253-2

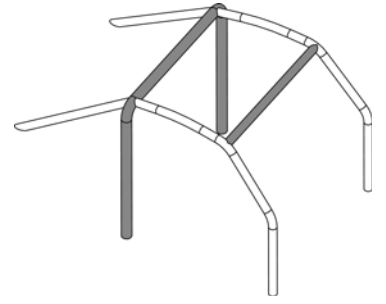

Dessin/Drawing 253-3

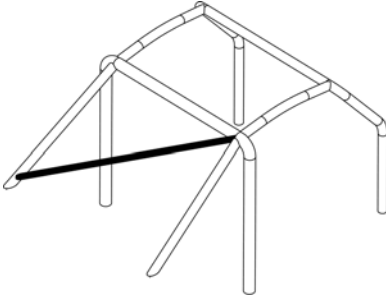

Dessin/Drawing 253-4

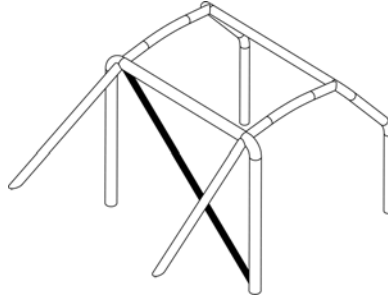

Dessin/Drawing 253-5

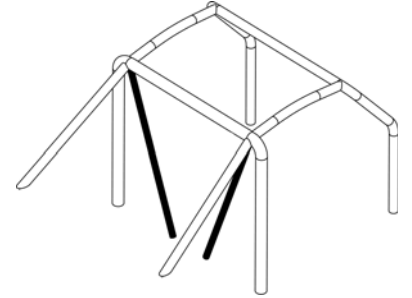

Dessin/Drawing 253-6

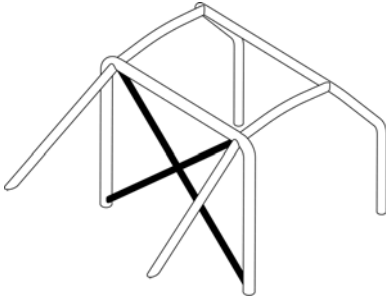

Dessin/Drawing 253-7

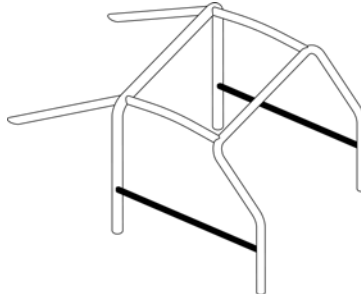

Dessin/Drawing 253-8

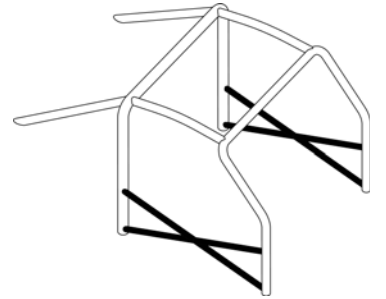

Dessin/Drawing 253-9

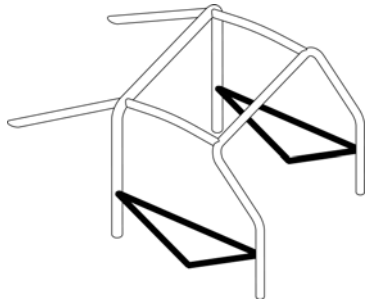

Dessin/Drawing 253-10

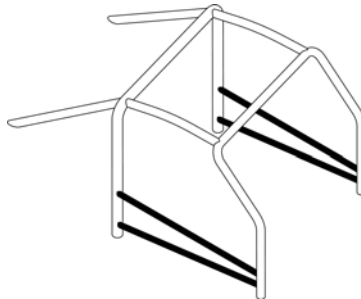

Dessin/Drawing 253-11

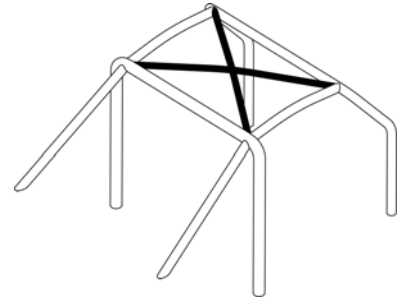

Dessin/Drawing 253-12

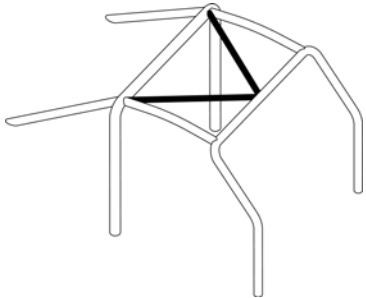

Dessin/Drawing 253-13

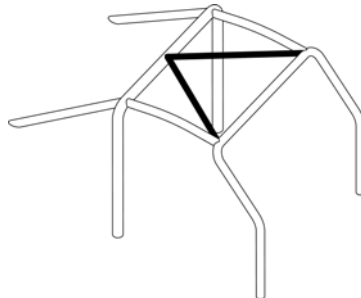

Dessin/Drawing 253-14

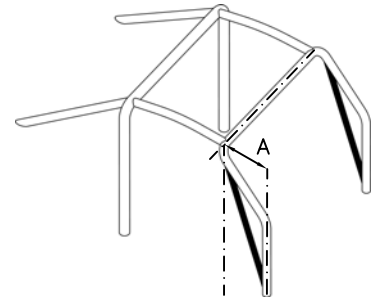

Dessin/Drawing 253-15

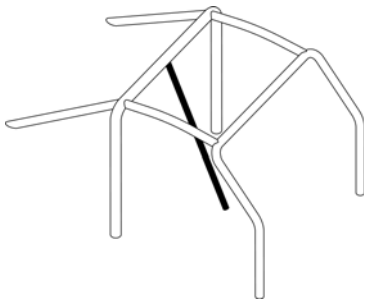

Dessin/Drawing 253-16

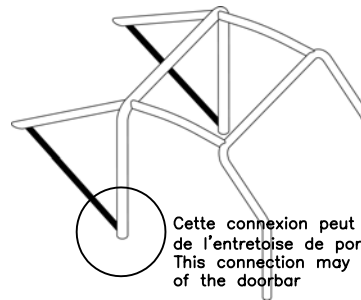

Dessin/Drawing 253-17

Cette connexion peut être au niveau de l'entretoise de portière
This connection may be at the level of the doorbar

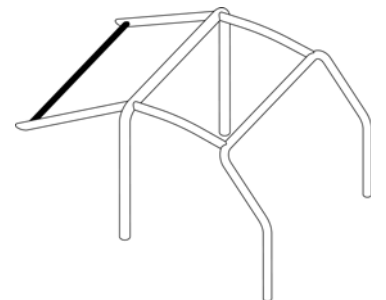

Dessin/Drawing 253-18

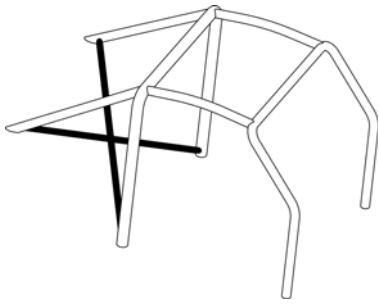

Dessin/Drawing 253-19

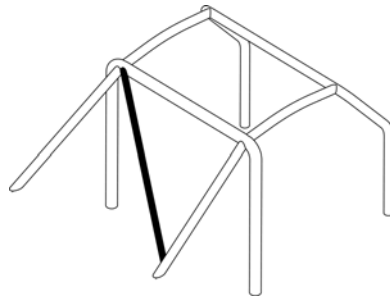

Dessin/Drawing 253-20

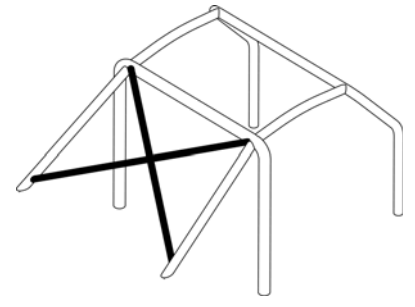

Dessin/Drawing 253-21

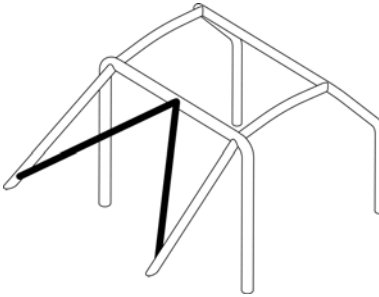

Dessin/Drawing 253-22

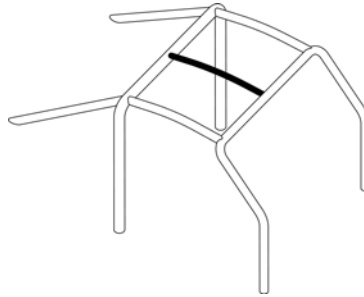

Dessin/Drawing 253-23

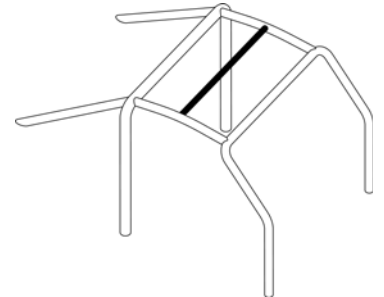

Dessin/Drawing 253-24

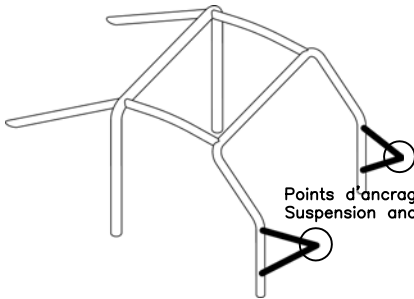

Points d'ancrage des suspensions
Suspension anchorage points

Dessin/Drawing 253-25

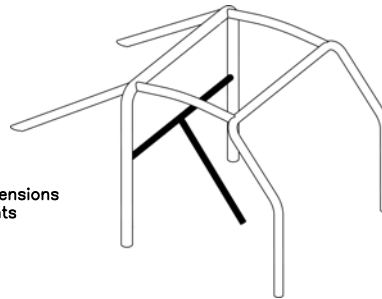

Dessin/Drawing 253-26

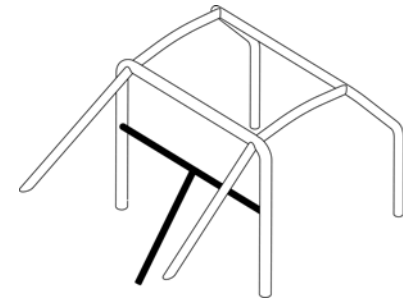

Dessin/Drawing 253-27

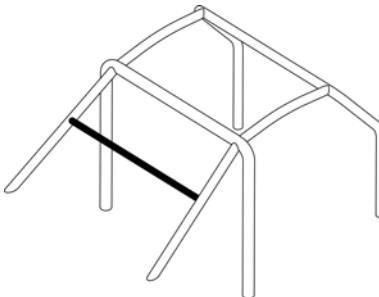

Dessin/Drawing 253-28

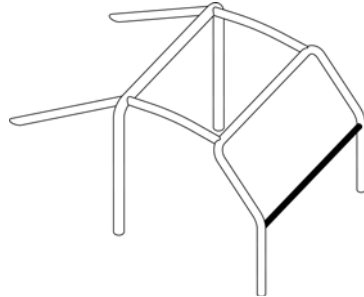

Dessin/Drawing 253-29

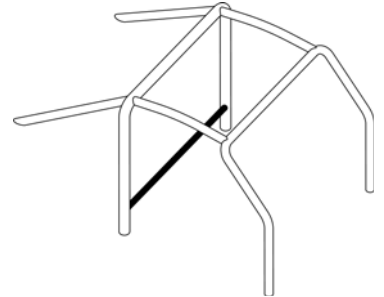

Dessin/Drawing 253-30

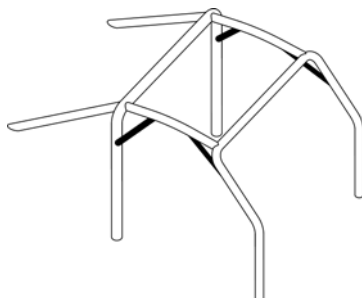

Dessin/Drawing 253-31

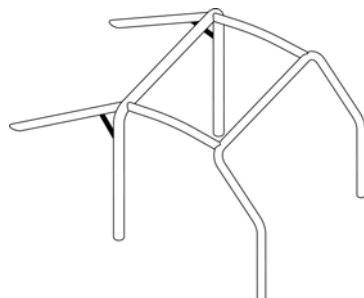

Dessin/Drawing 253-32

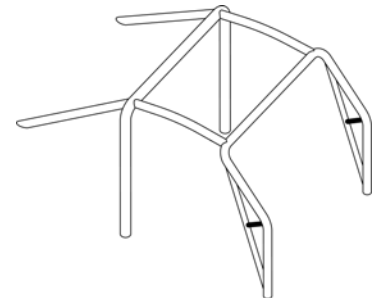

Dessin/Drawing 253-33

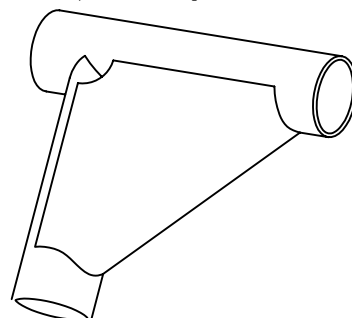

Dessin/Drawing 253-34

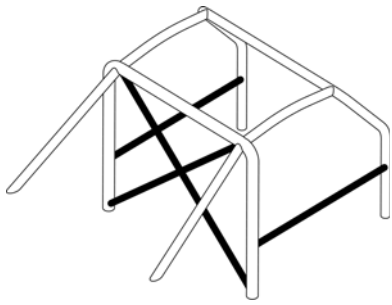

Dessin/Drawing 253-35A

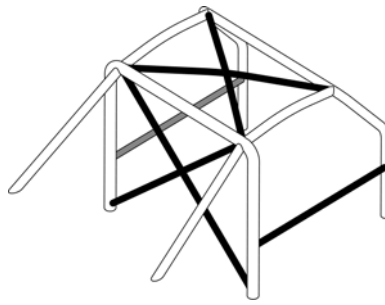

Dessin/Drawing 253-35B

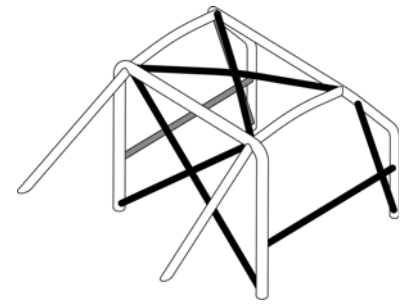

Dessin/Drawing 253-35C

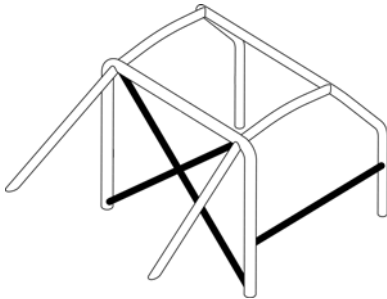

Dessin/Drawing 253-36A

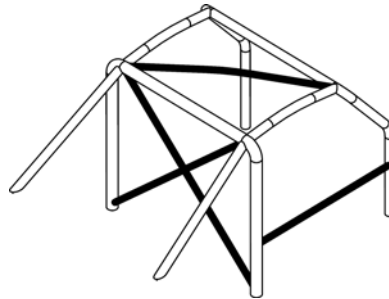

Dessin/Drawing 253-36B

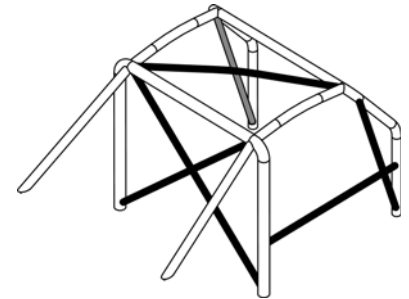

Dessin/Drawing 253-36C

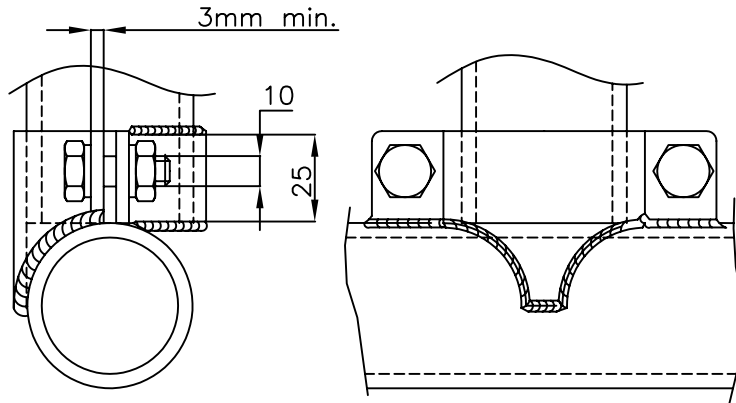

Dessin/Drawing 253-37

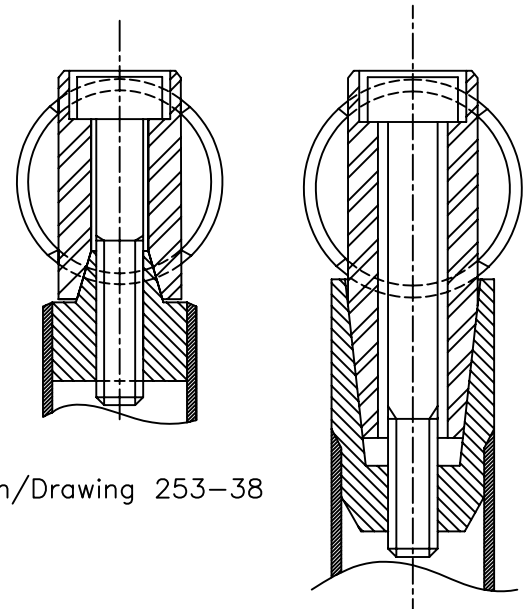

Dessin/Drawing 253-38

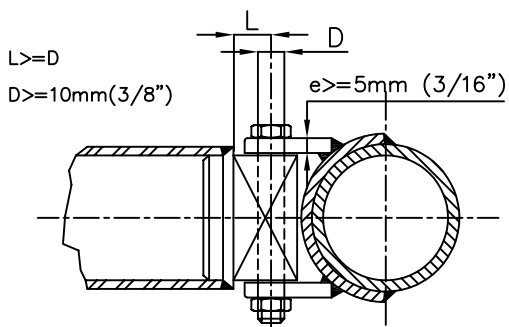

Dessin/Drawing 253-40

Dessin/Drawing 253-39

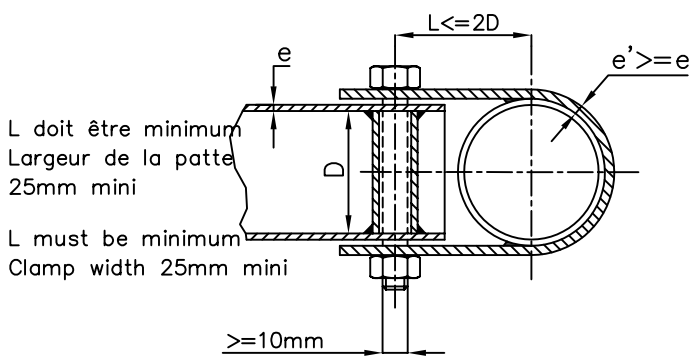

Dessin/Drawing 253-43

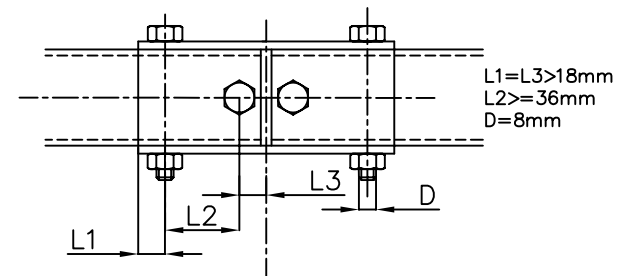

Dessin/Drawing 253-41

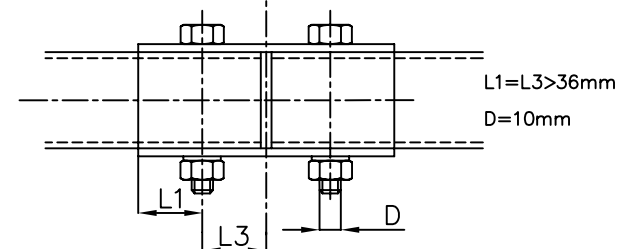

Dessin/Drawing 253-42

soudure
welding

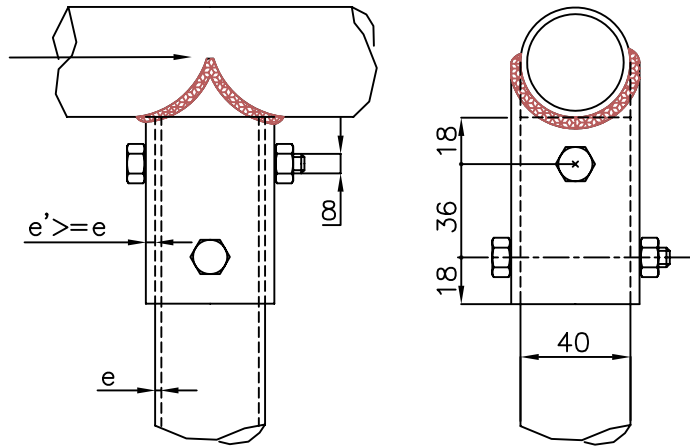

(Dimensions en/in mm)

Dessin/Drawing 253-44

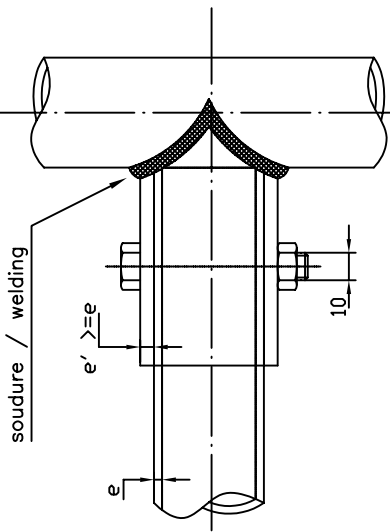

Dessin/Drawing 253-45

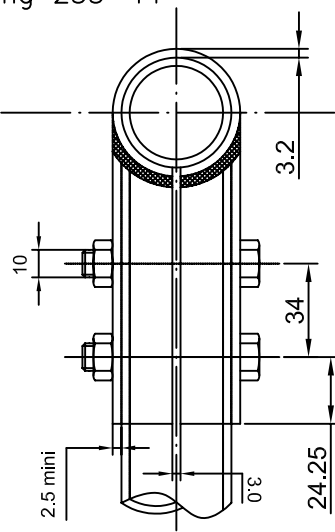
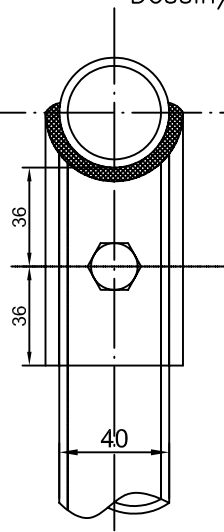

Dessin/Drawing 253-46

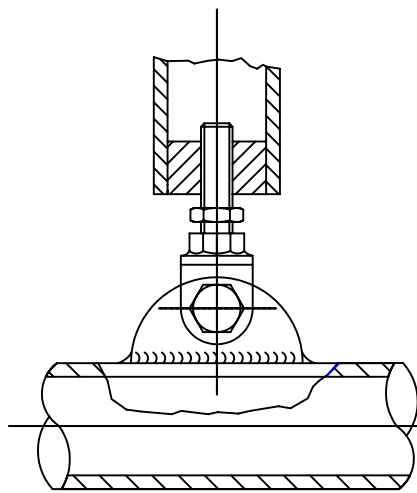
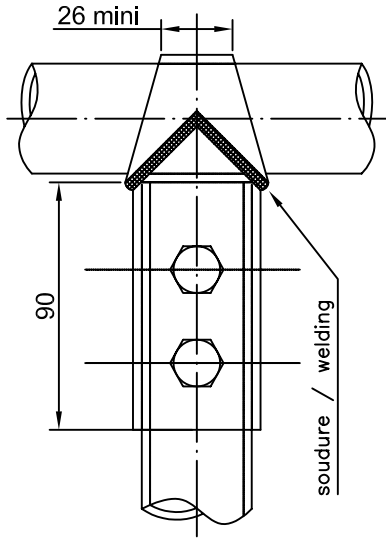

Dessin/Drawing 253-47

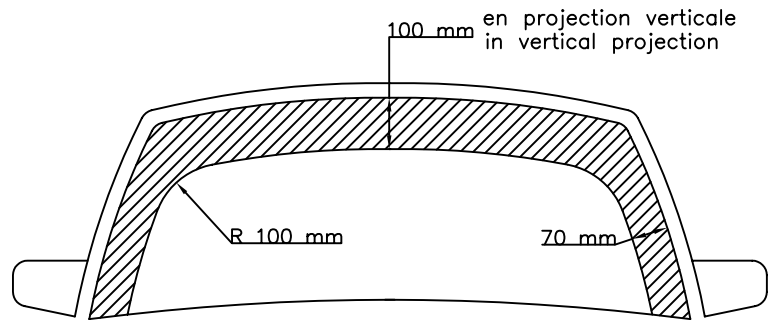
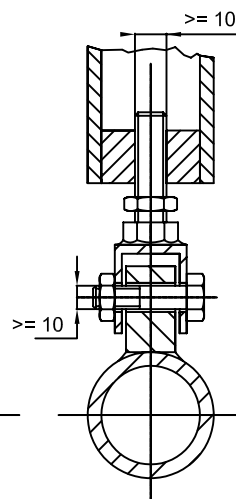

Dessin/Drawing 253-48

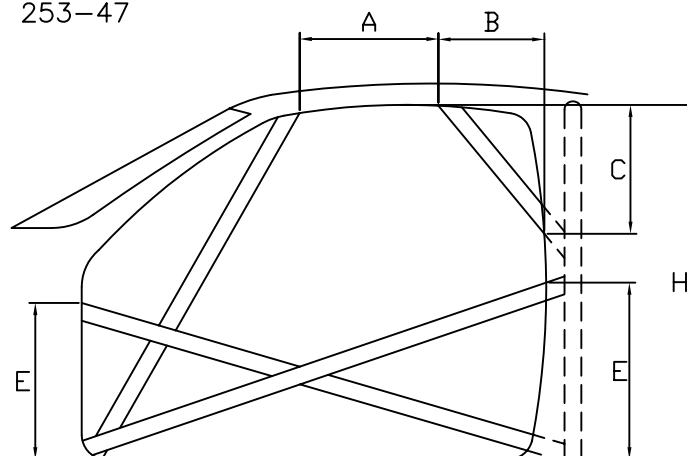

Dessin/Drawing 253-49

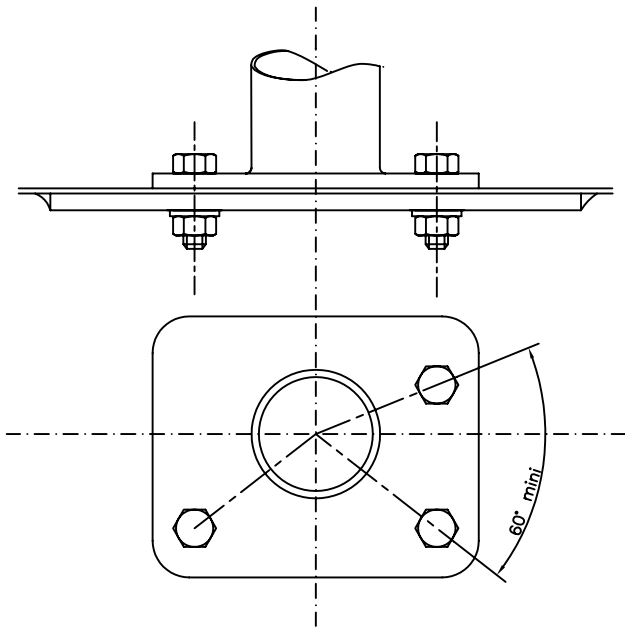

Dessin/Drawing 253-50

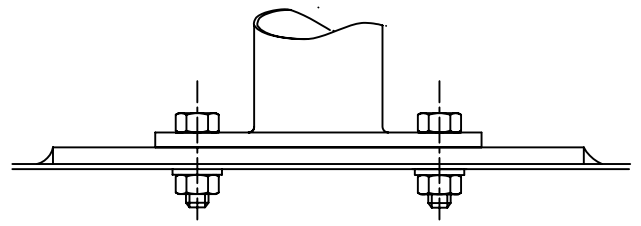

Dessin/Drawing N°253-51

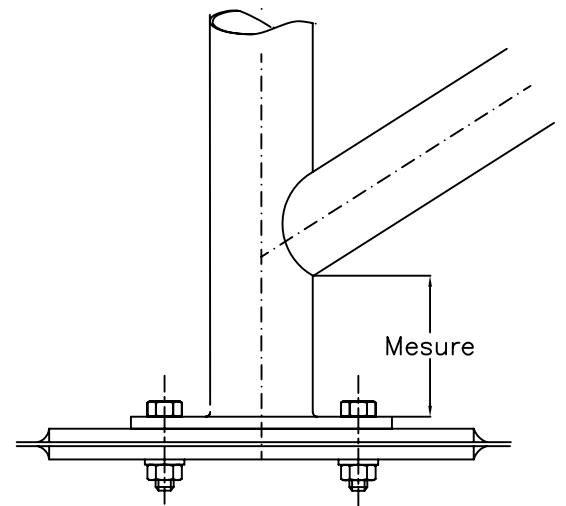

Dessin/Drawing 253-52

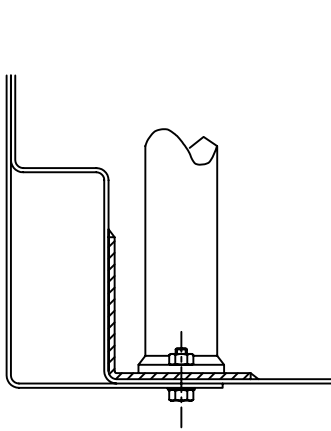

Dessin/Drawing 253-53

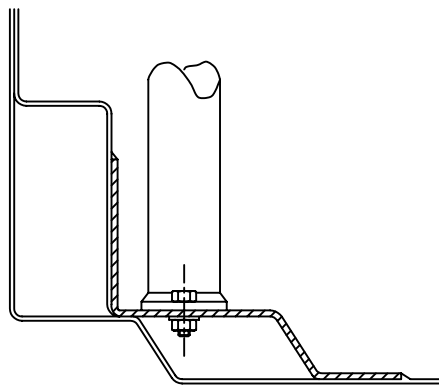

Dessin/Drawing 253-54

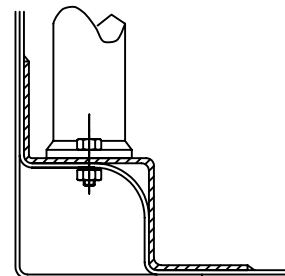

Dessin/Drawing 253-55

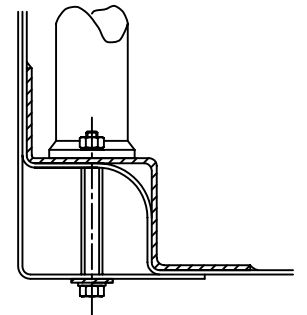

Dessin/Drawing 253-56

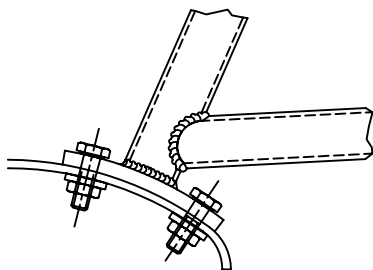

Dessin/Drawing 253-57

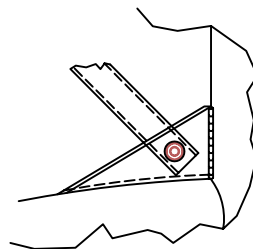

Dessin/Drawing 253-58

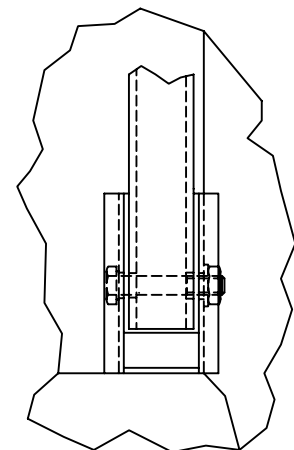

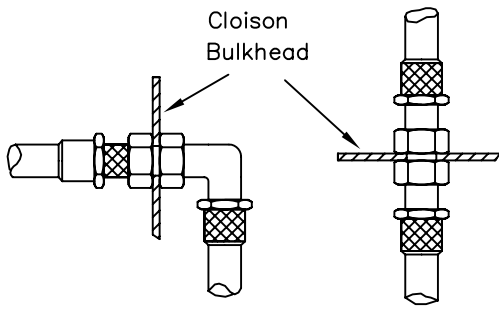

Dessin/Drawing 253-59

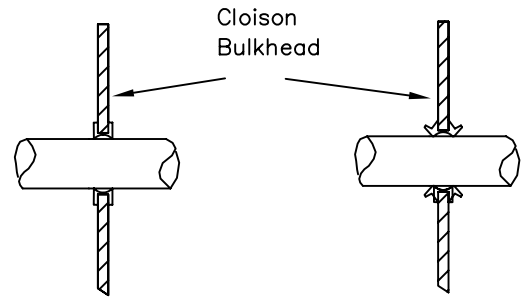

Dessin/Drawing 253-60

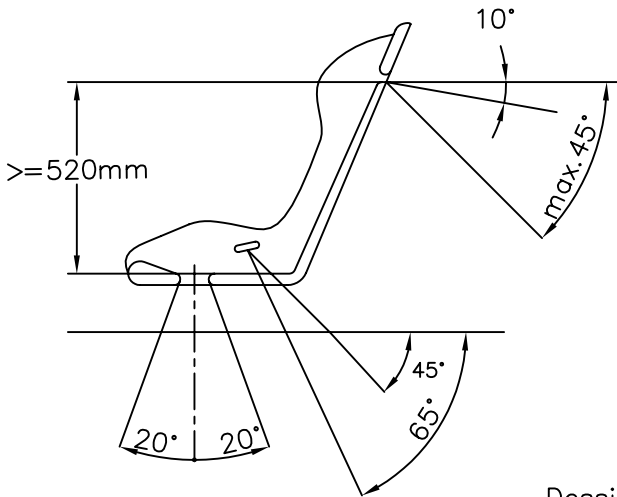

Dessin/Drawing 253-61

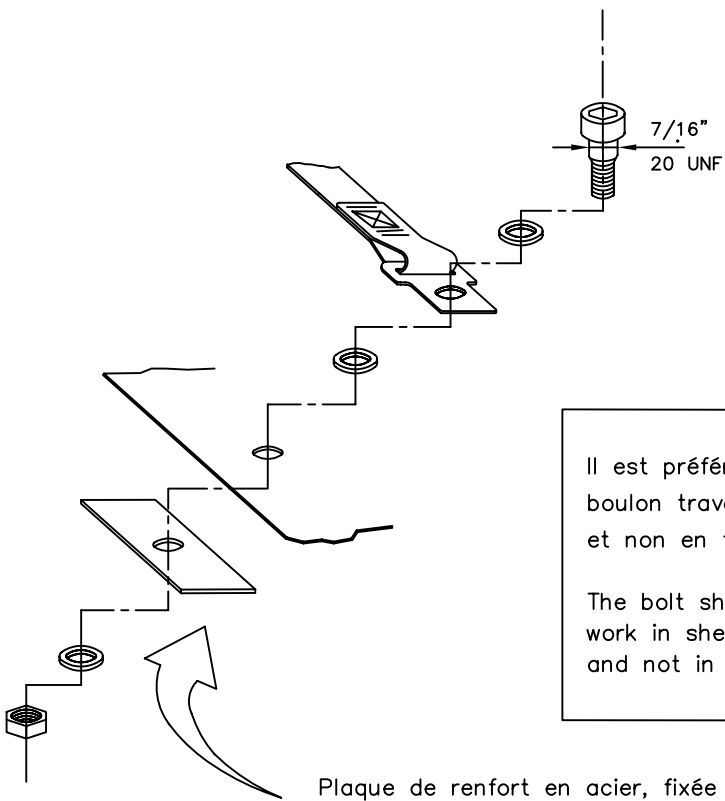
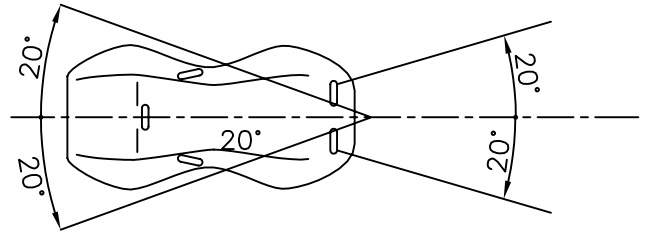

Il est préférable que le
boulon travaille en cisaillement
et non en traction

The bolt should preferably
work in shearing stress
and not in traction

Plaque de renfort en acier, fixée
au châssis de la voiture
Steel reinforcing plate fixed
to the car's chassis

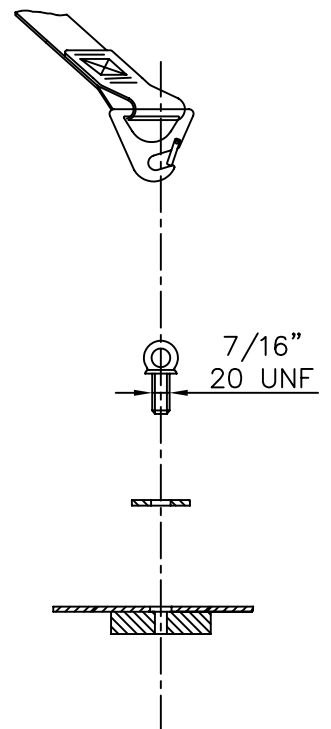

Dessin/Drawing 253-62

plaque fixée au châssis de la voiture et renforcée
de l'autre côté par une plaque de renfort

plate fixed to the chassis and strengthened
by a reinforced plate on the other side

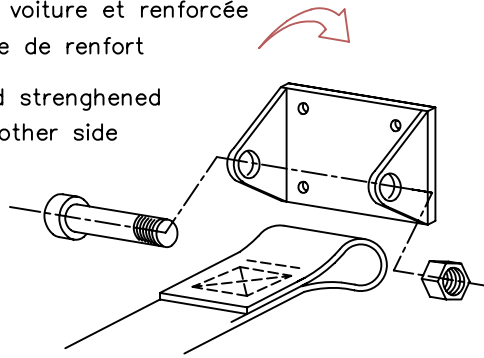

Dessin/Drawing 253-63

plaque de renfort fixée au châssis de la voiture
reinforcing plate fixed to the car's chassis

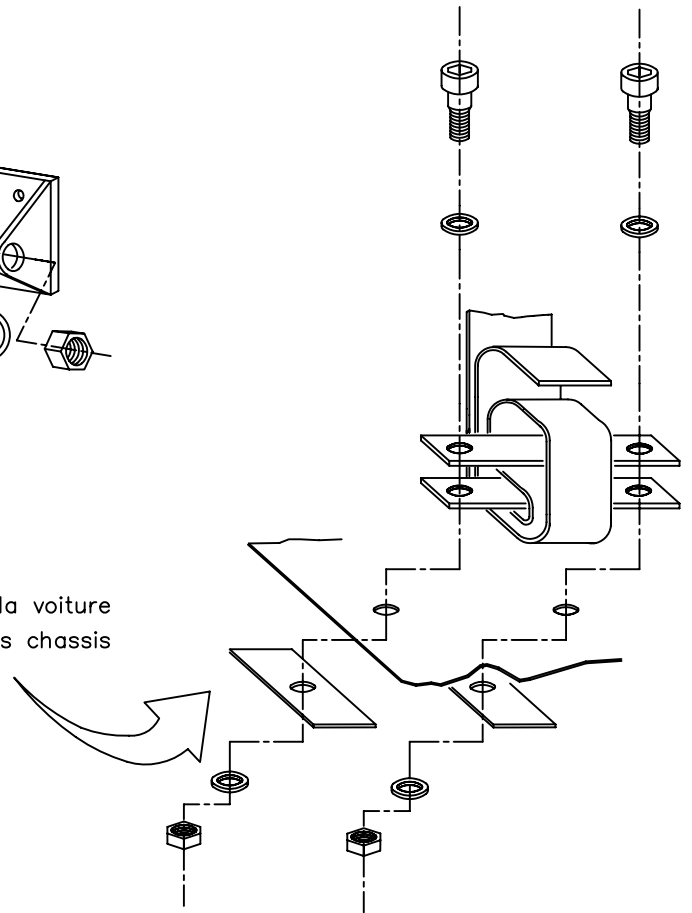

Dessin/Drawing 253-64

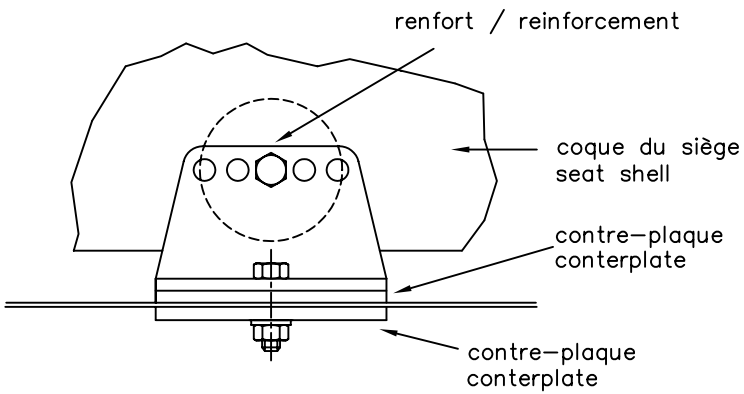

Dessin/Drawing 253-65

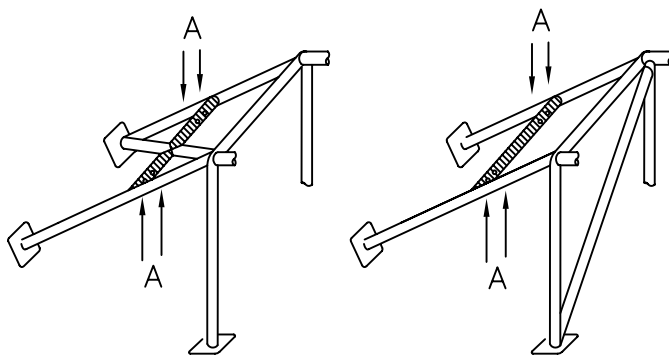

Ⓐ trous de montage pour harnais
mounting holes for harness

Dessin/Drawing 253-66

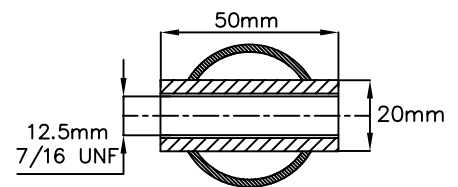

Dessin/Drawing 253-67

INTERDICTION DE SOUDER LES PLATINES SUR LES CONTRE PLAQUES
END PLATES MUST NOT BE WELDED ON THE COUNTERPLATES

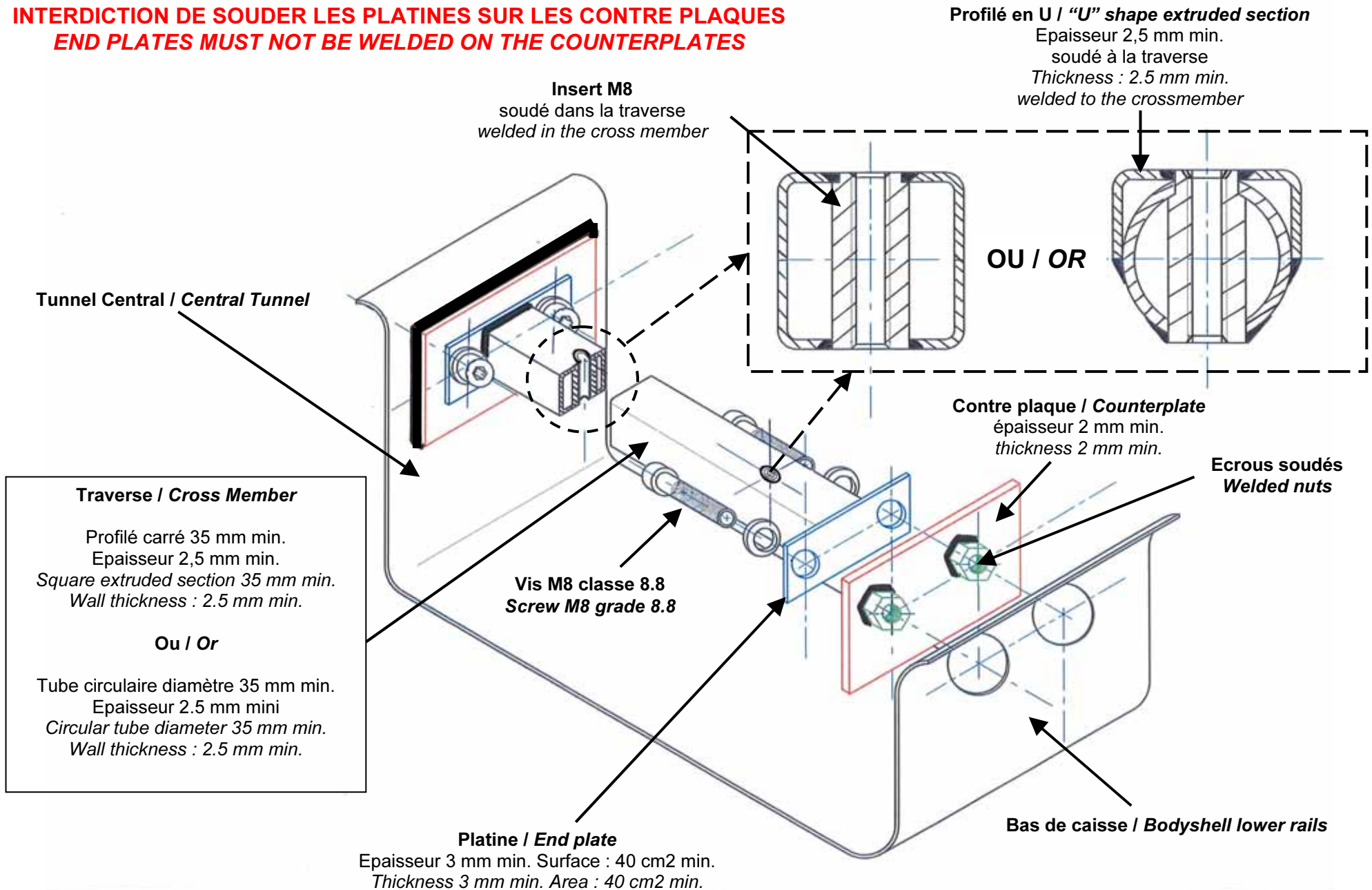

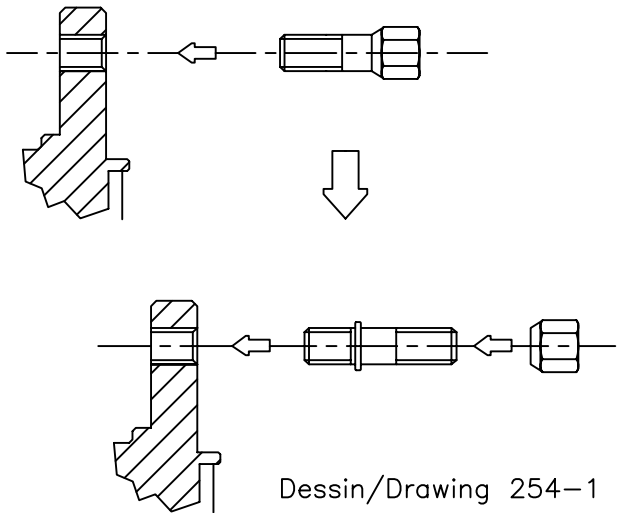

Dessin/Drawing 254-1

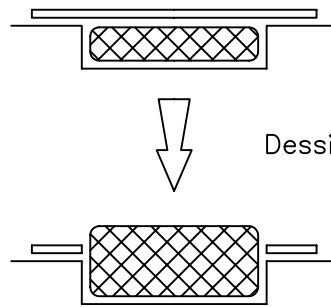

Dessin/Drawing 254-2

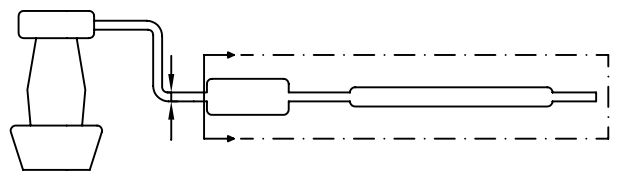

Dessin/Drawing 254-3

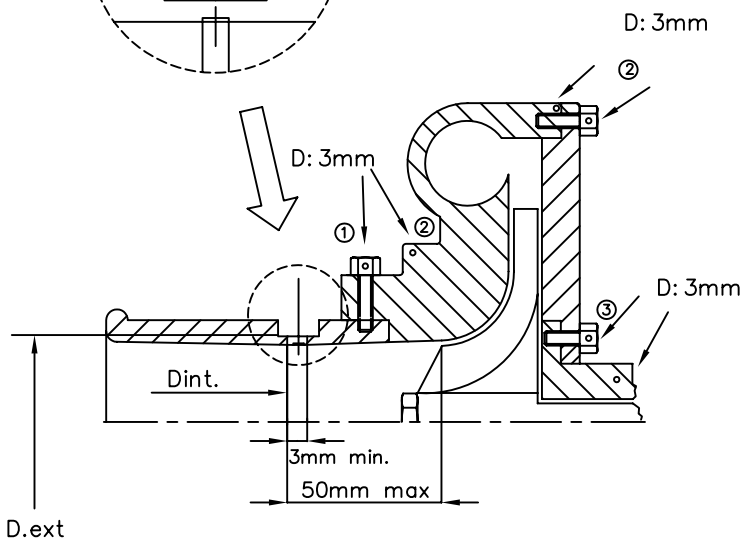
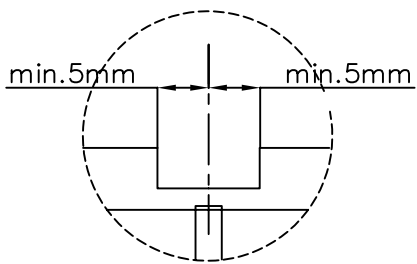

- ① trou pour bride ou bride/carter de compression
hole for restrictor/compressor housing
- ② trou pour carter de compression ou carter/flasque
hole for compressor housing or housing/flange
- ③ trou pour carter central ou carter/flasque
hole for central housing or housing/flange

AUTRES POSSIBILITES :

OTHER POSSIBILITES :

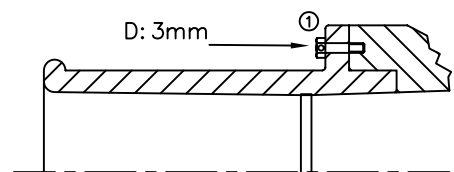
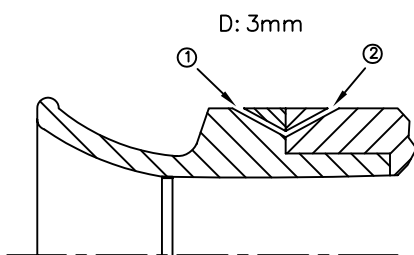

Dessin/Drawing 254-4

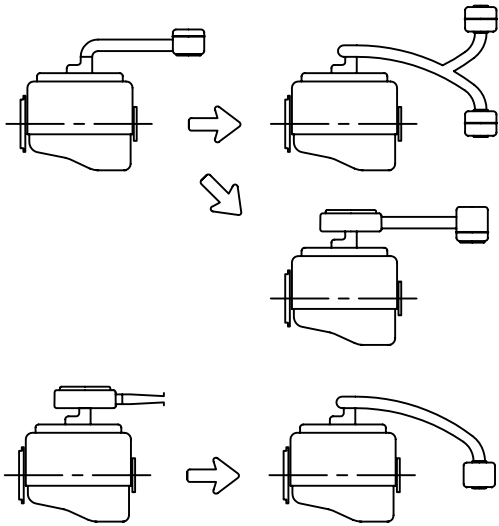

Dessin/Drawing 255-1

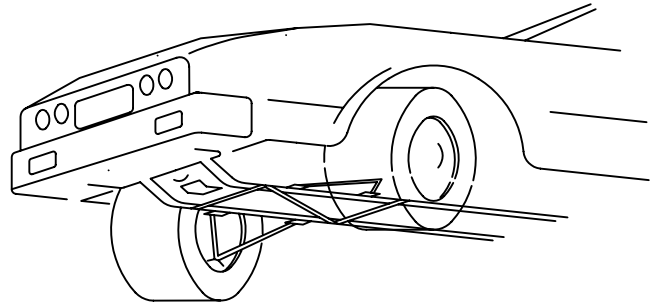

Dessin/Drawing 255-2

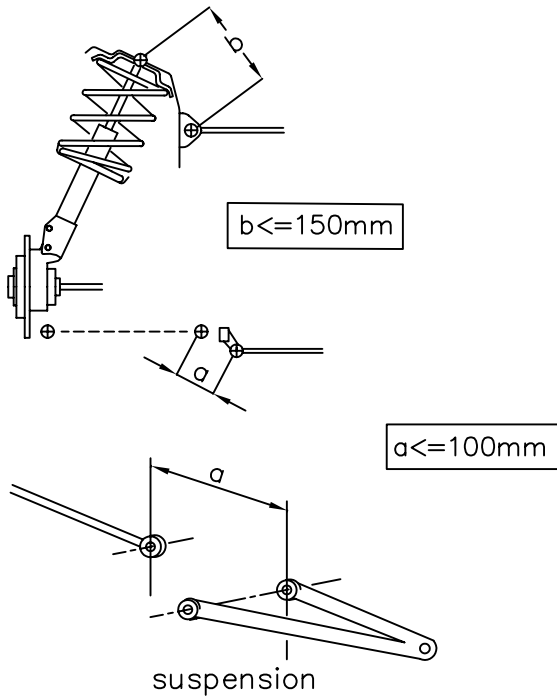

Dessin/Drawing 255-4

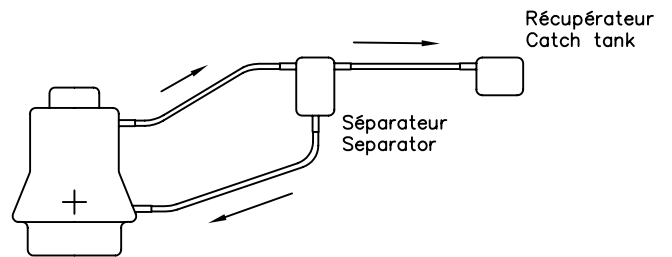

Dessin/Drawing 255-3

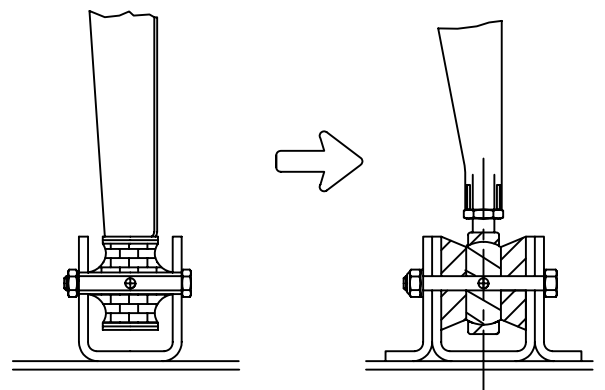

Dessin/Drawing 255-5

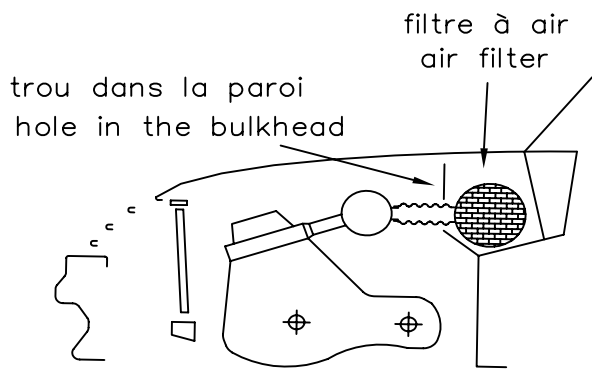

Dessin/Drawing 255-6

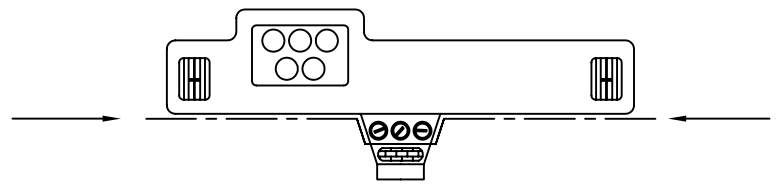

Dessin/Drawing 255-7

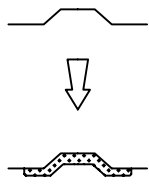

Dessin/Drawing 255-8

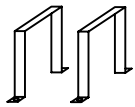
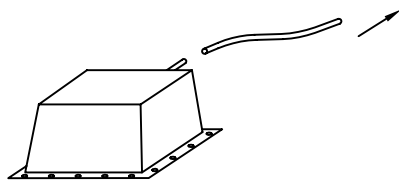

Dessin/Drawing 255-10

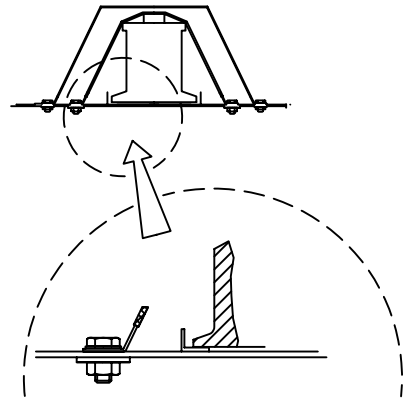
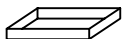
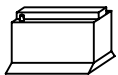

Dessin/Drawing 255-11

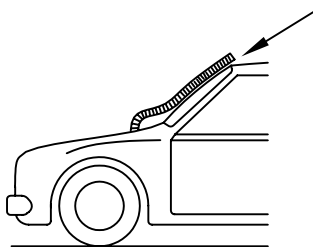

Dessin/Drawing 255-13

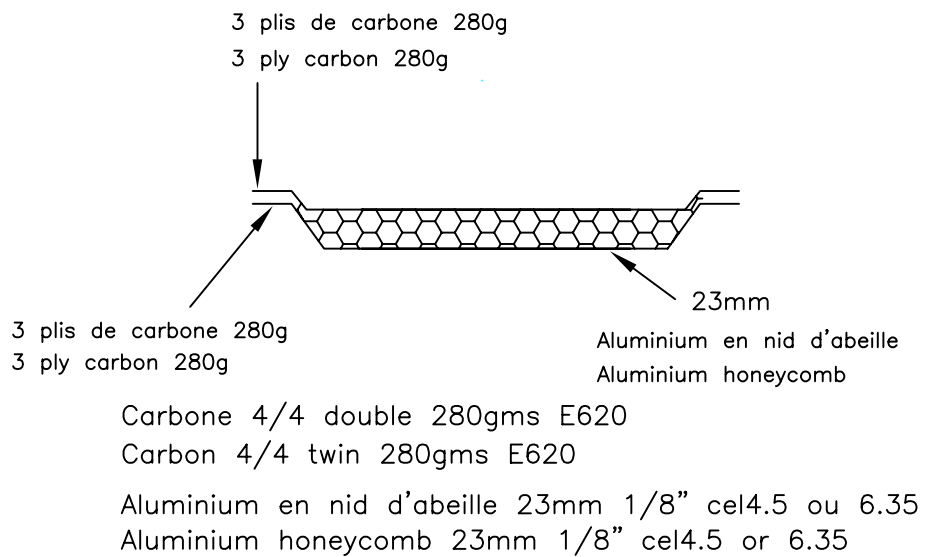

Dessin/Drawing 255-14

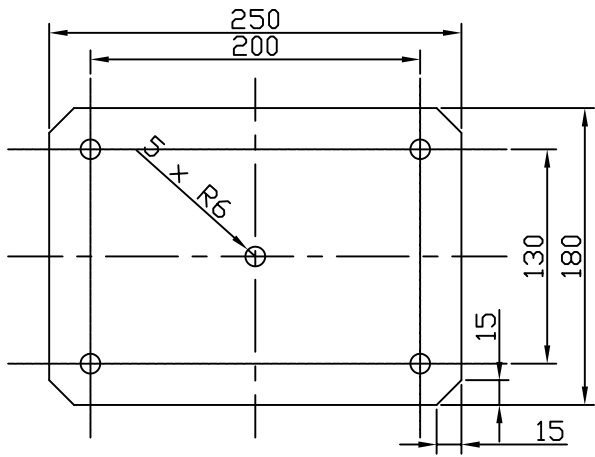

Dessin/Drawing 257-1

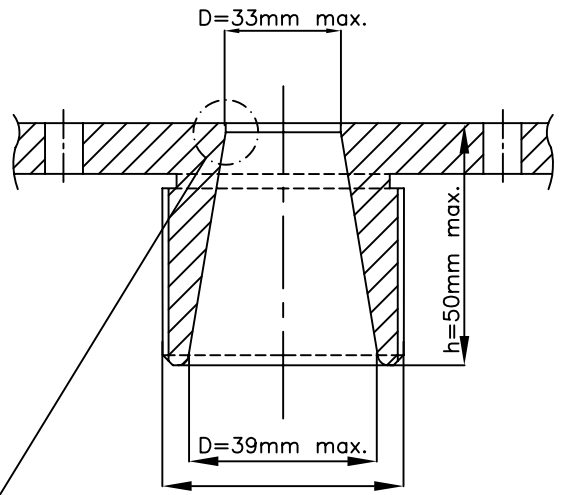

Pour vanne
1/4 de tour
For quarter
turn valve

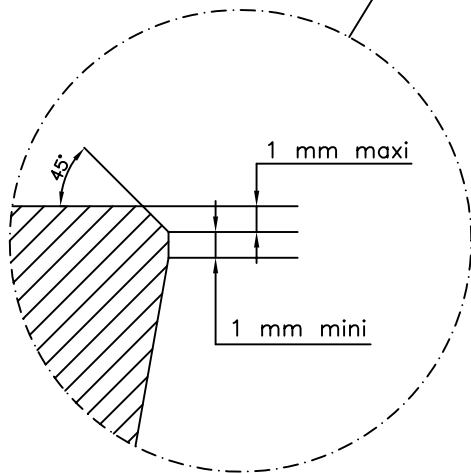

Dessin /Drawing 257-3

Detail B

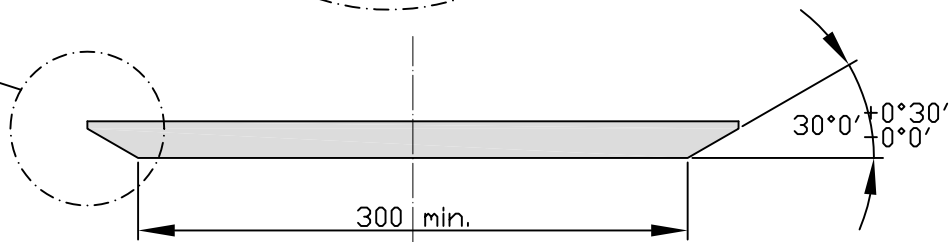

Section B-B

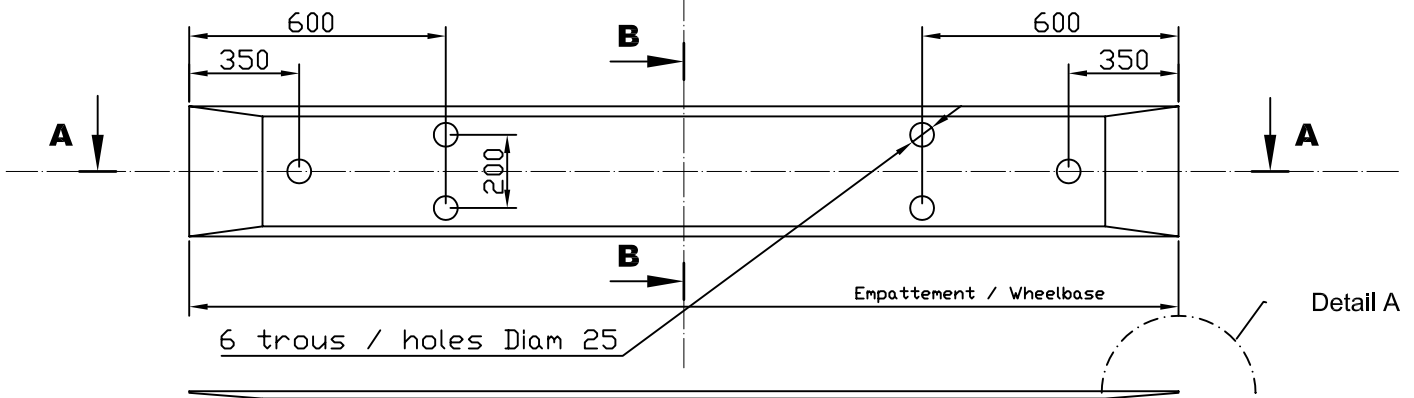

Section A-A

Detail A

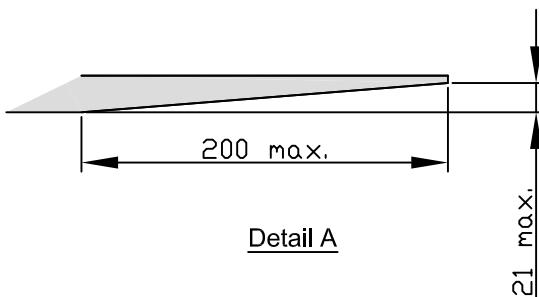

Detail A

Dessin /Drawing 257-2

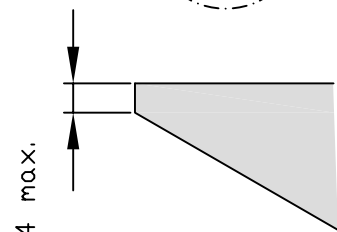

Detail B

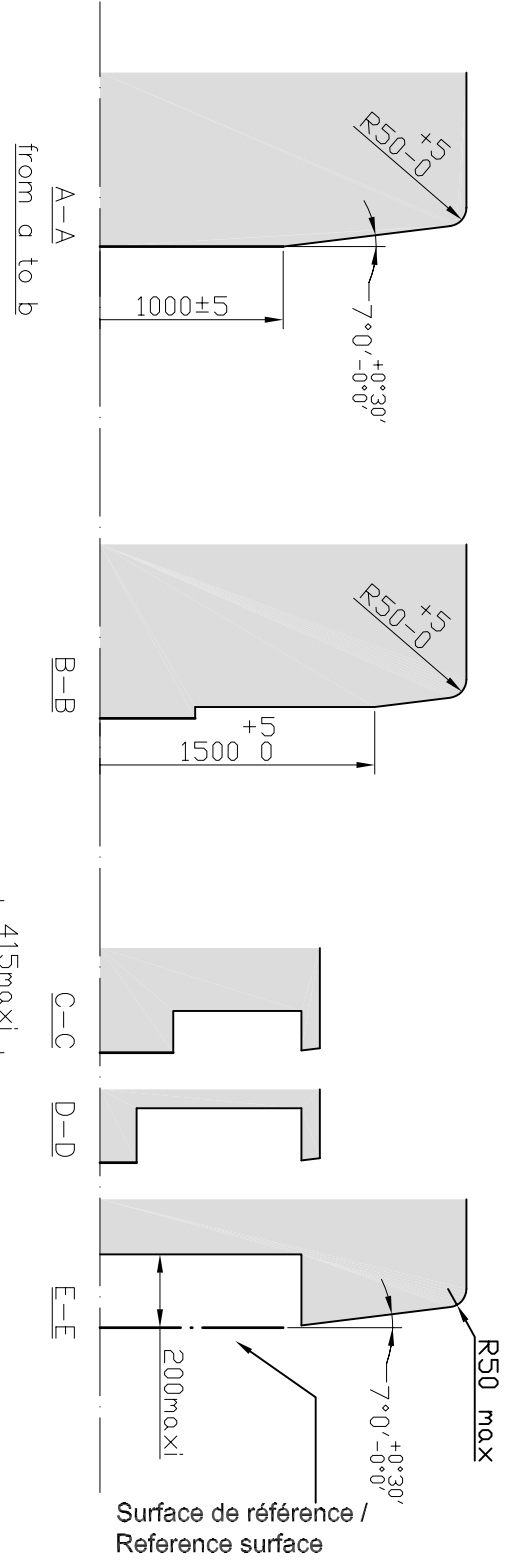
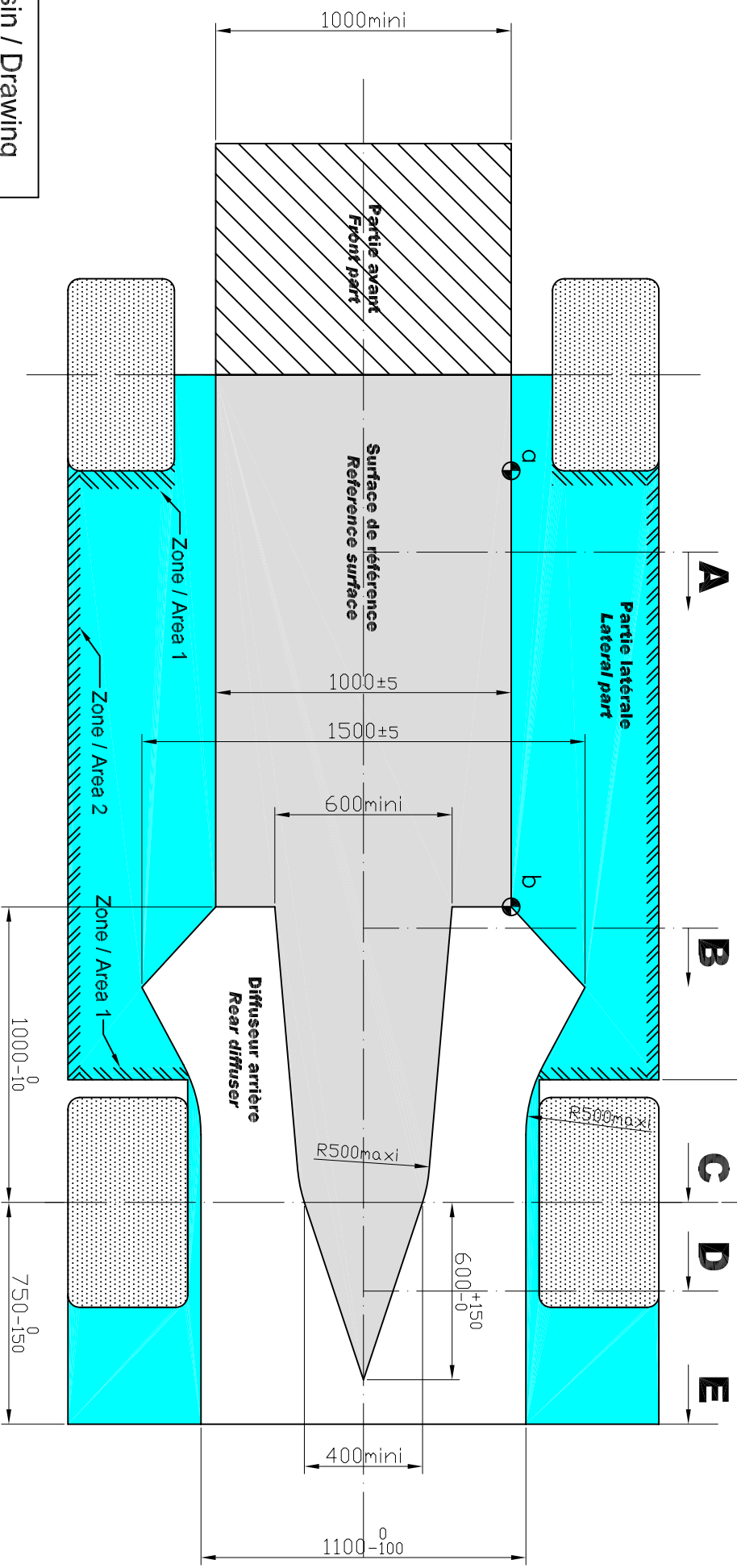

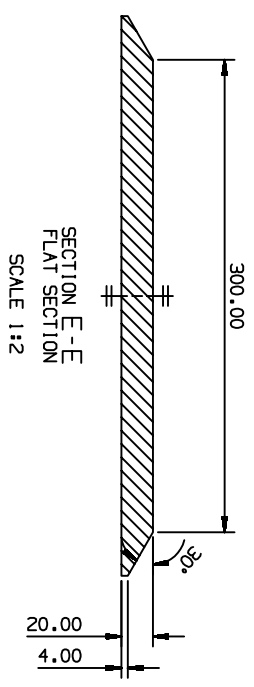
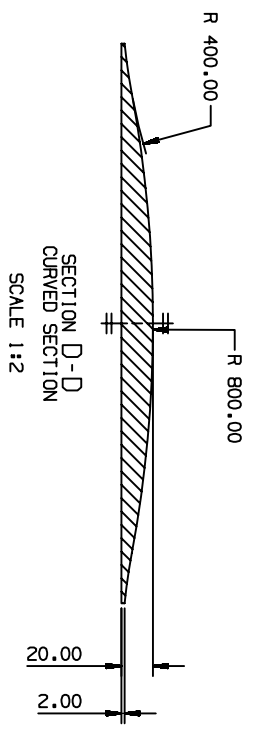
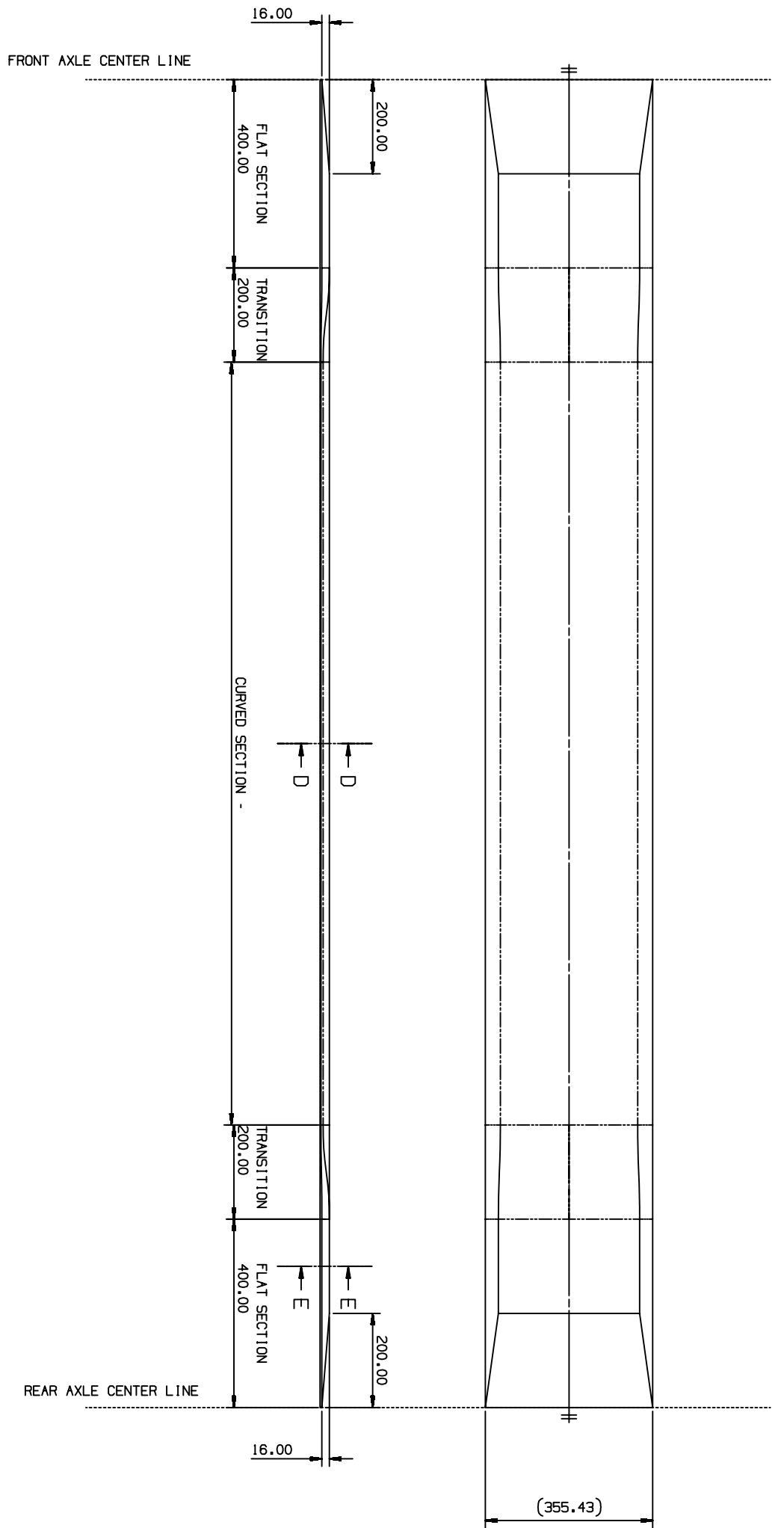

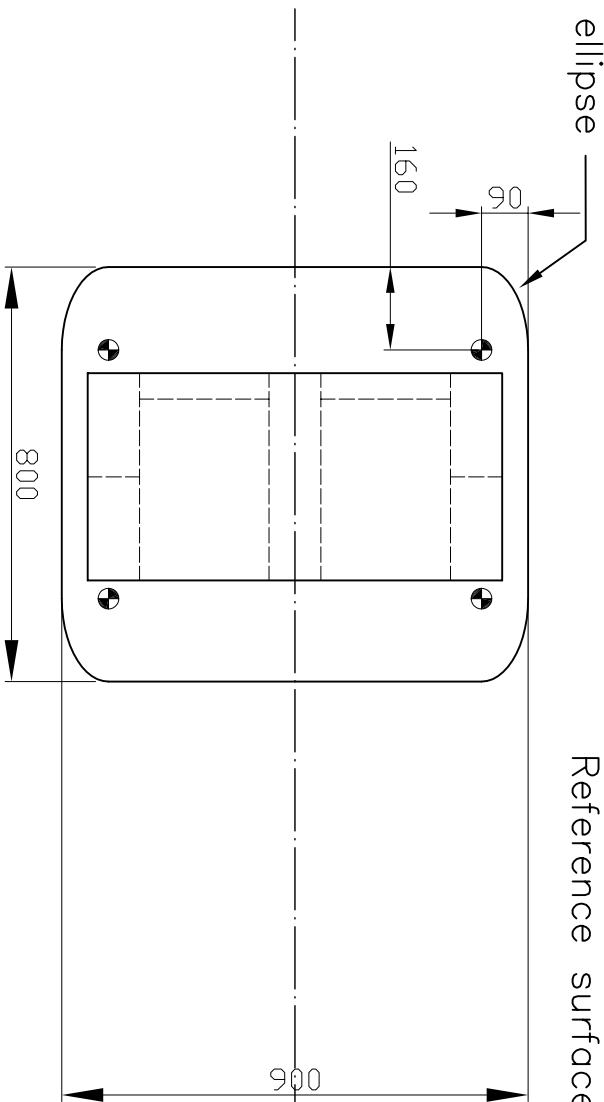
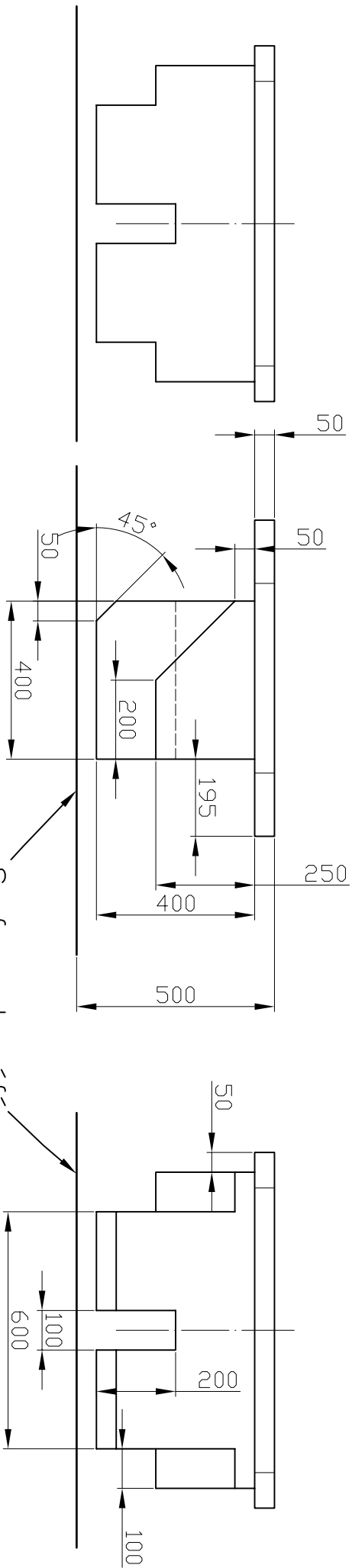

Axe longitudinal voiture
Car's longitudinal centerline

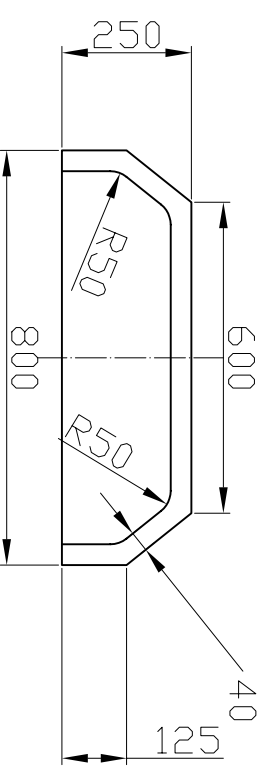
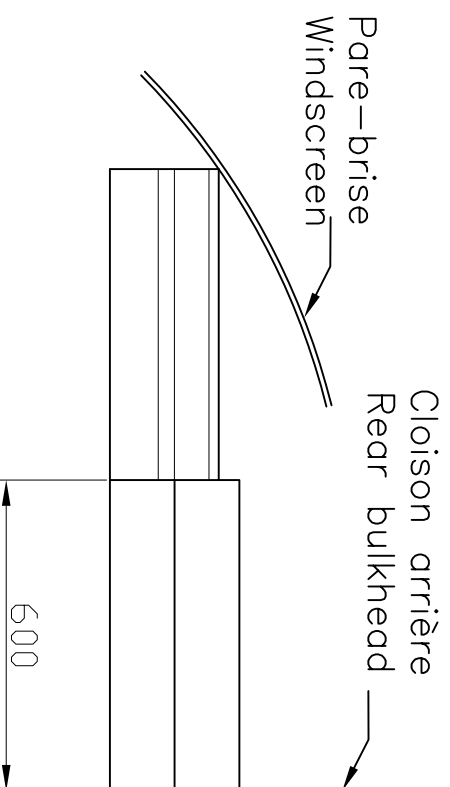

Dessin / Drawing n°258A-4
 Gabarit / Template n°2

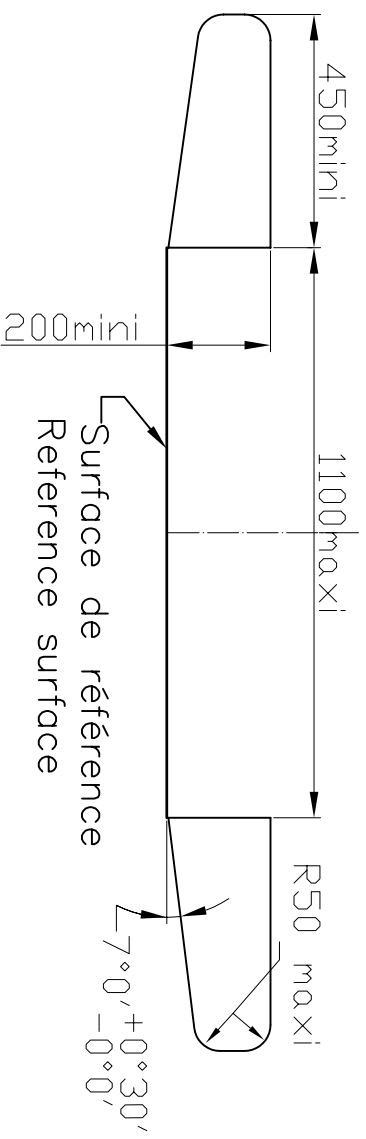

Dessin / Drawing n°258A-5

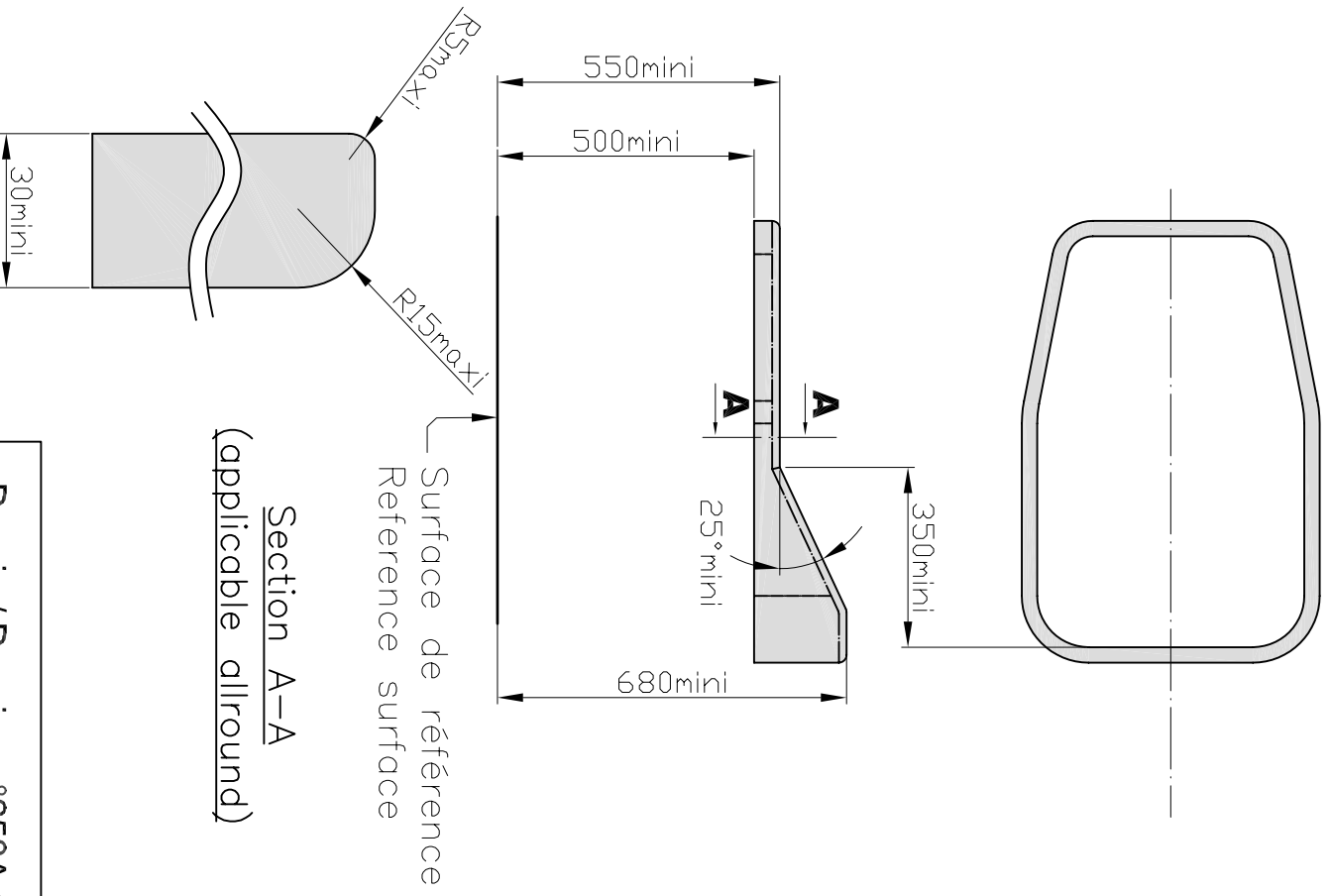

Surface de référence
 Reference surface
 Section A-A
 (applicable allround)

Dessin / Drawing n°258A-6

Axe longitudinale voiture
 Car's longitudinal centreline

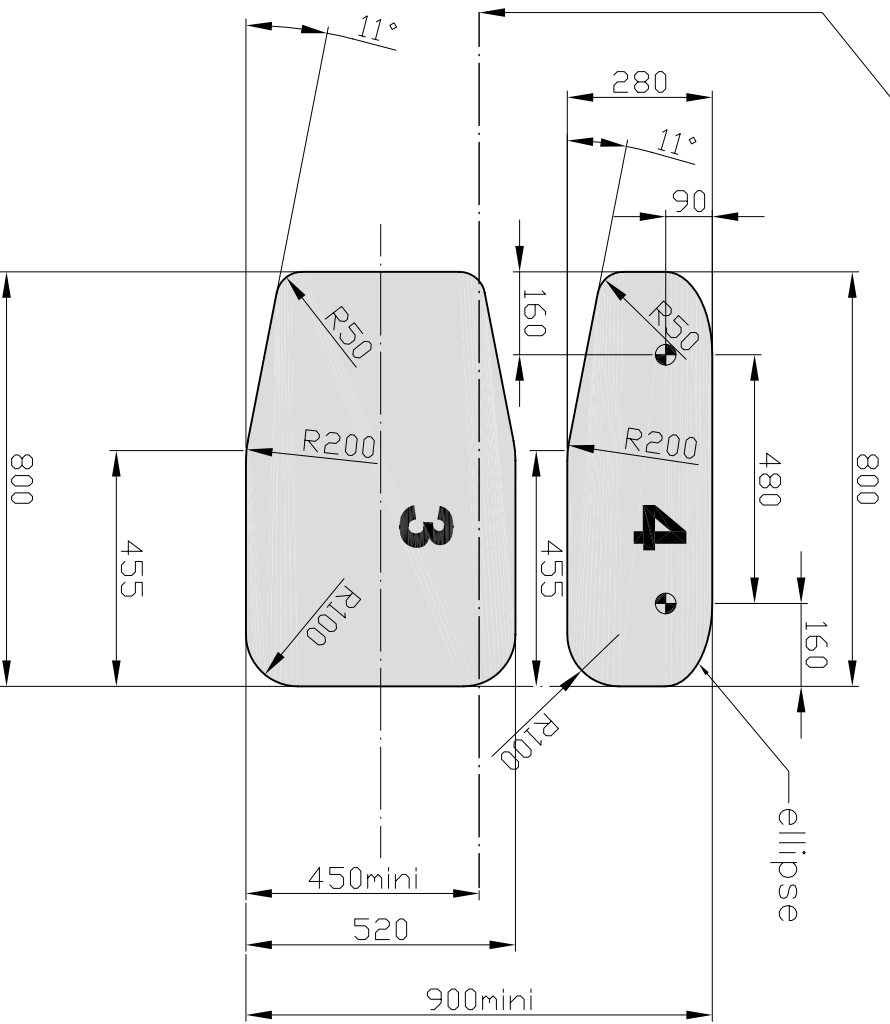

Dessin / Drawing n°258A-7
 Gabarits / Templates n° 3 and 4

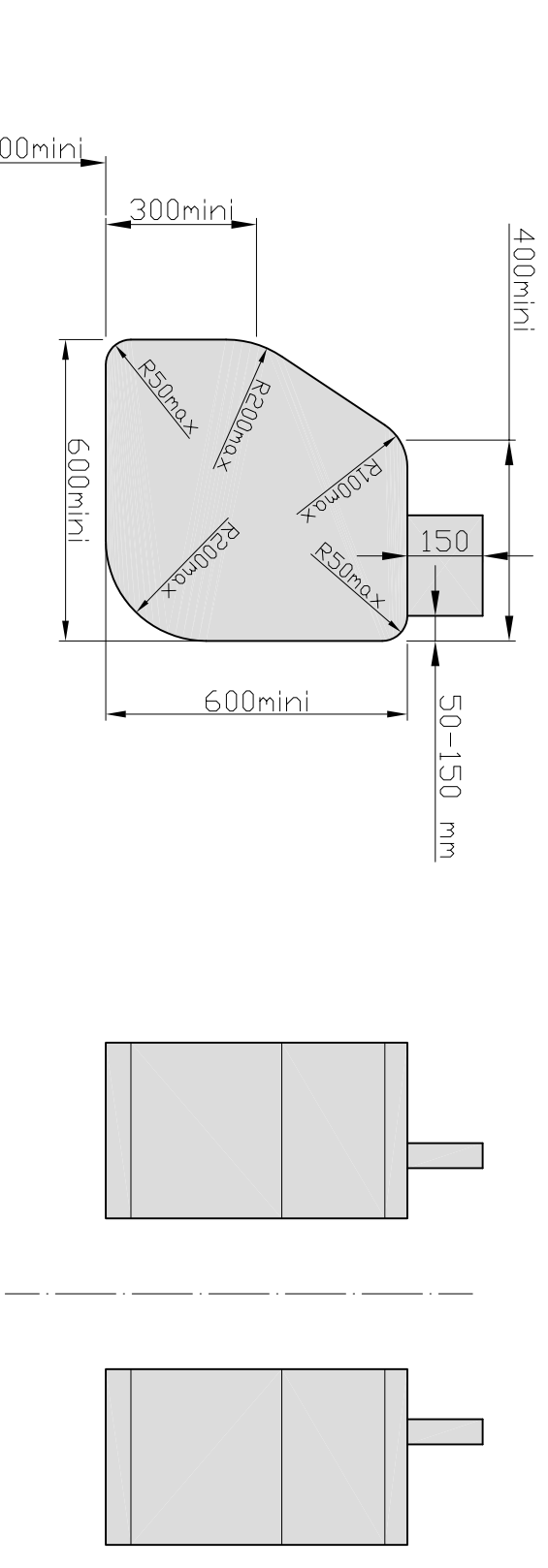

Surface de référence
Reference surface

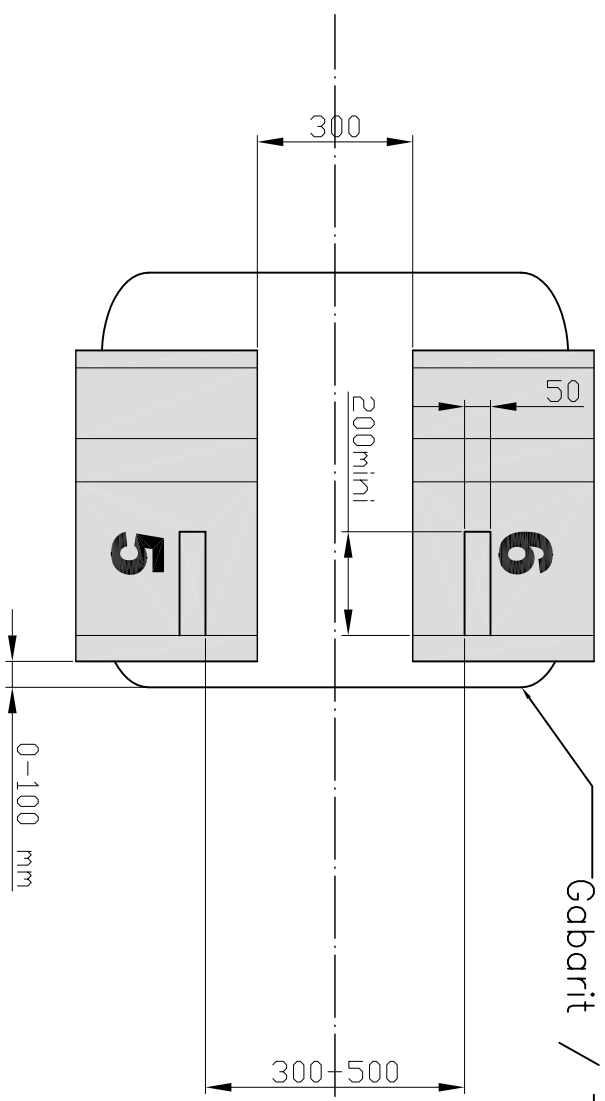

Gabarit / Template n°1

Axe longitudinal voiture
Car's longitudinal centreline

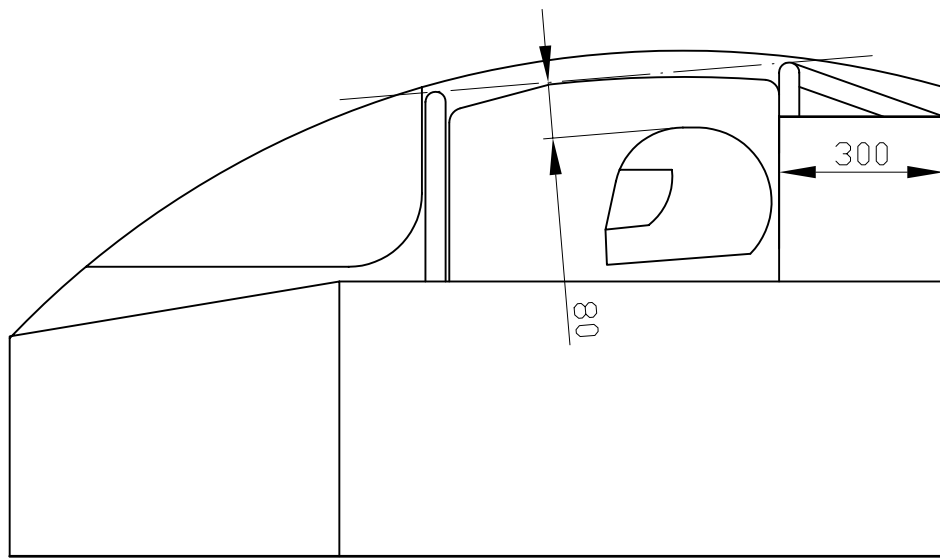
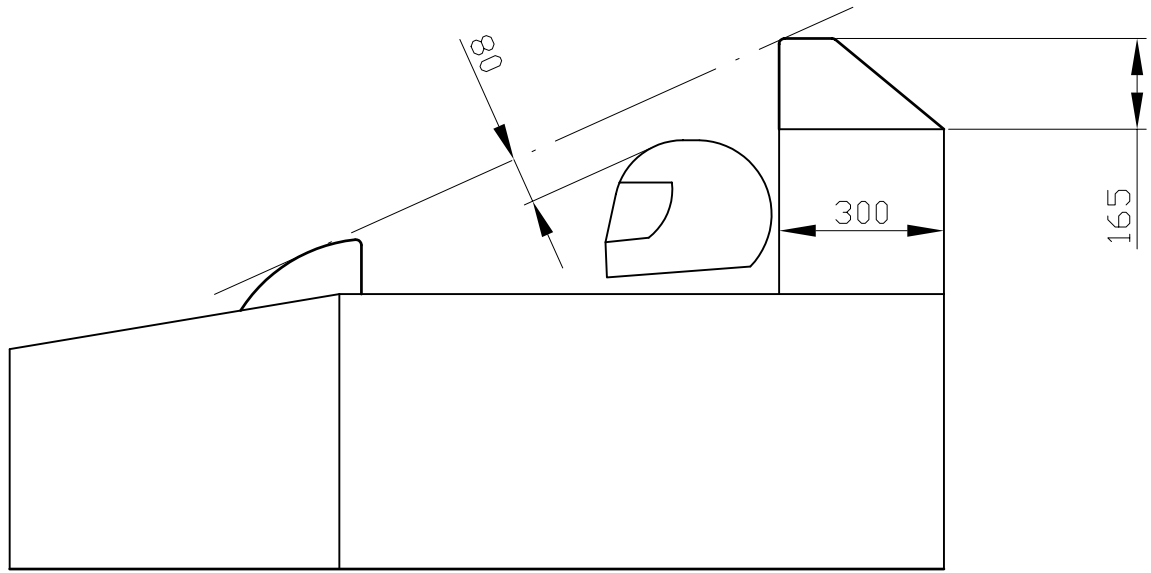

Dessin / Drawing
258A-9

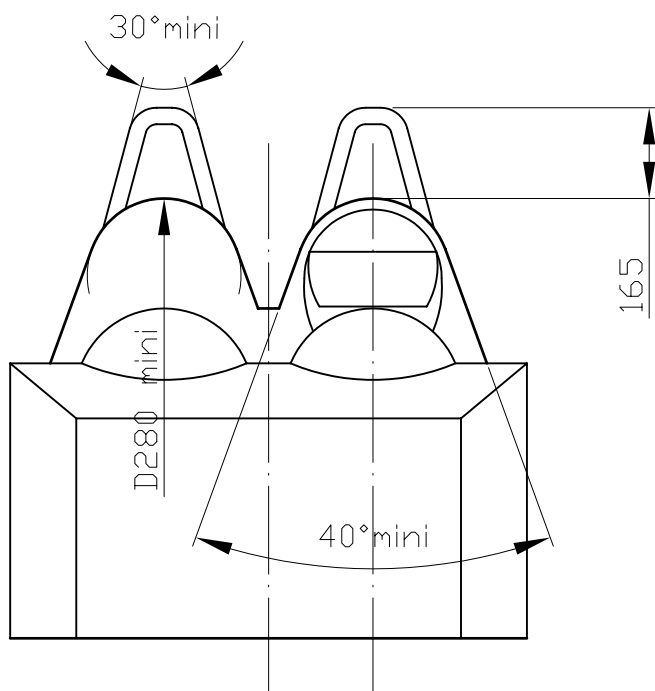

Dessin / Drawing
258A-10

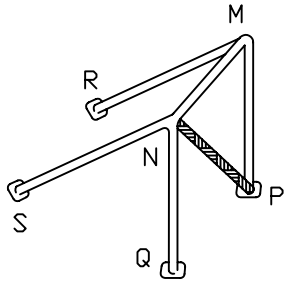

Dessin/Drawing 259-1

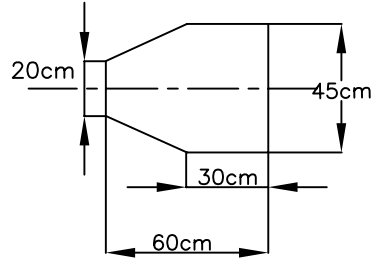

Dessin/Drawing 259-2

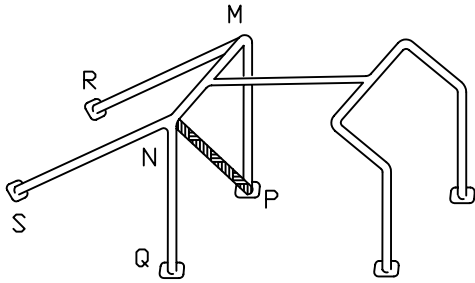

Dessin/Drawing 259-3

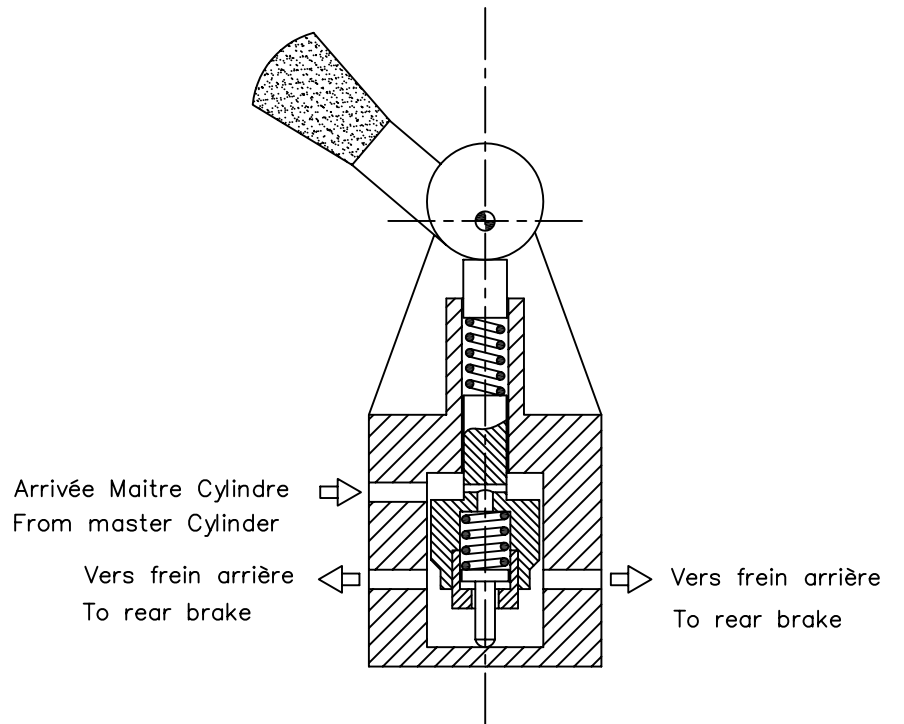

Dessin/Drawing N°263-9

Dimensions en/in millimètres.

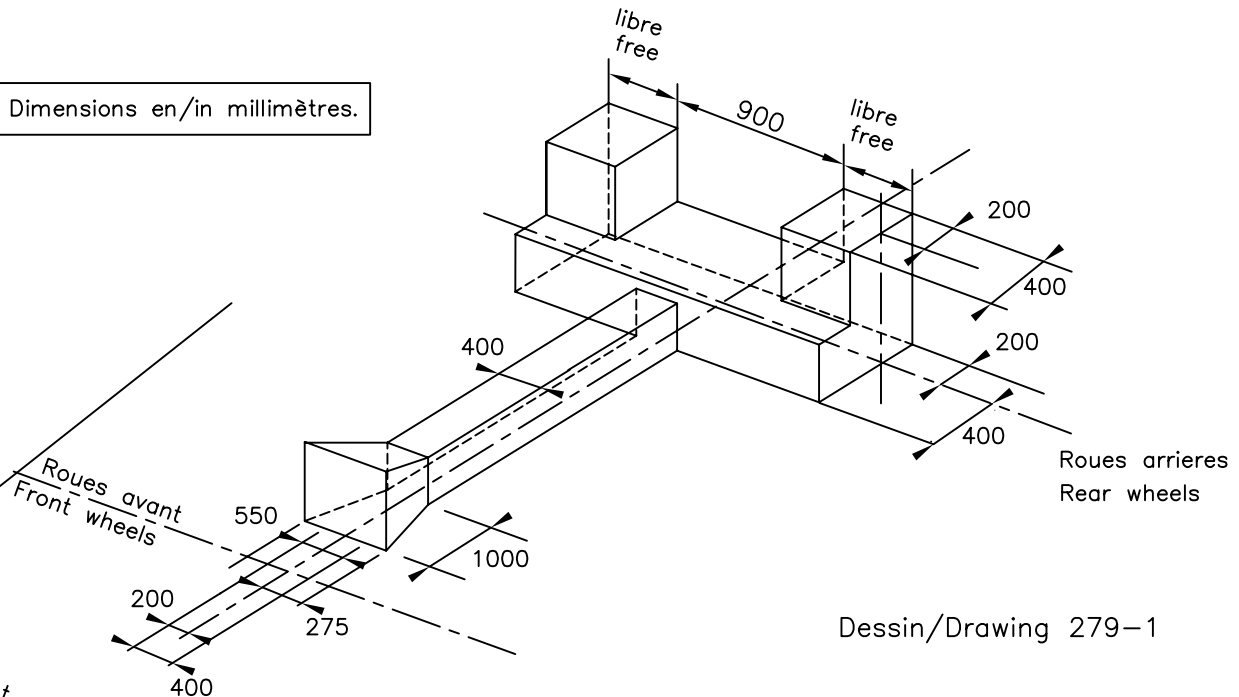

Dessin/Drawing 279-1

Plan passant par le point le plus bas du plancher
Plane passing through the lowest point of the floor

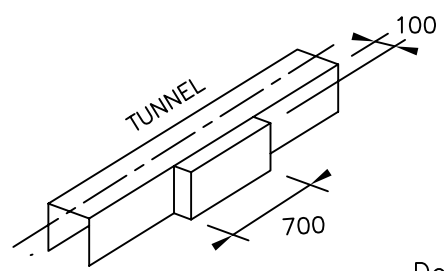
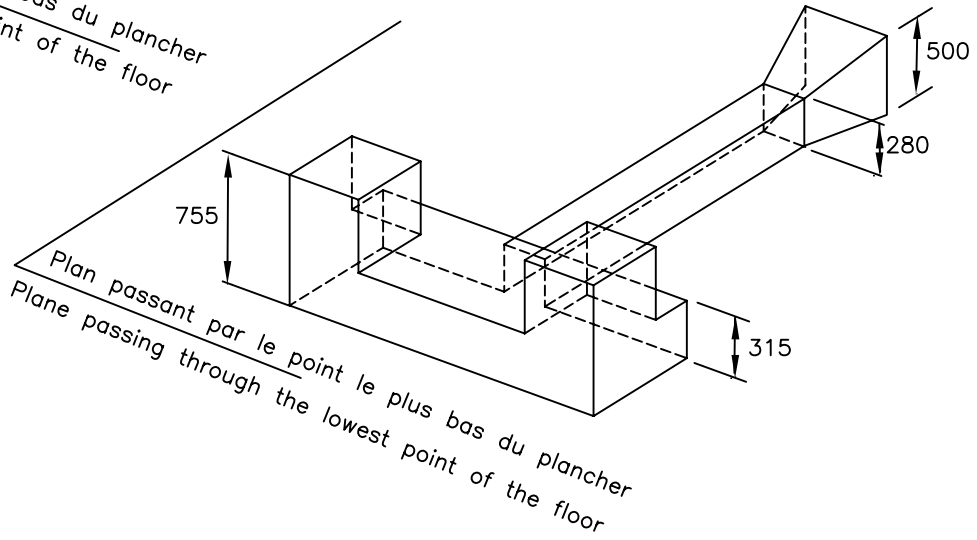

Dessin/Drawing 279-2

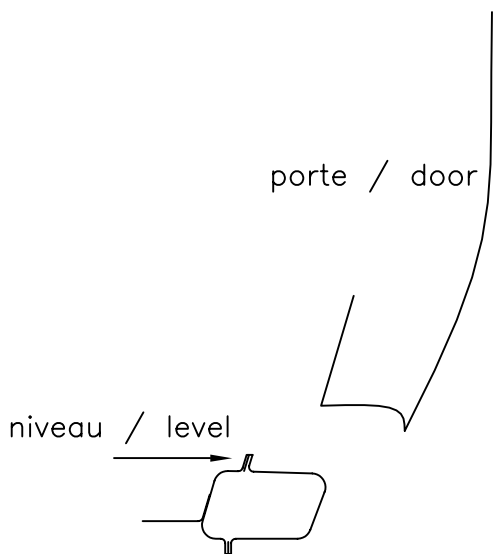

Dessin/Drawing 279-3

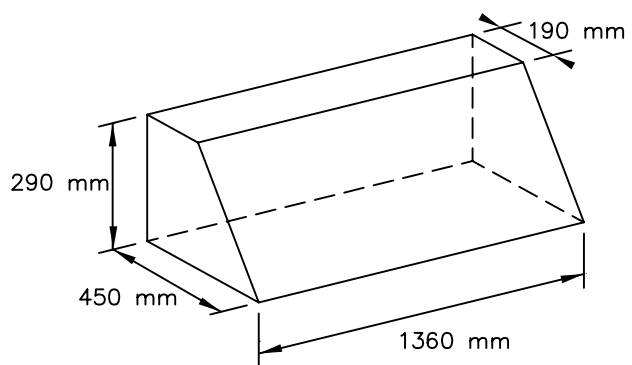
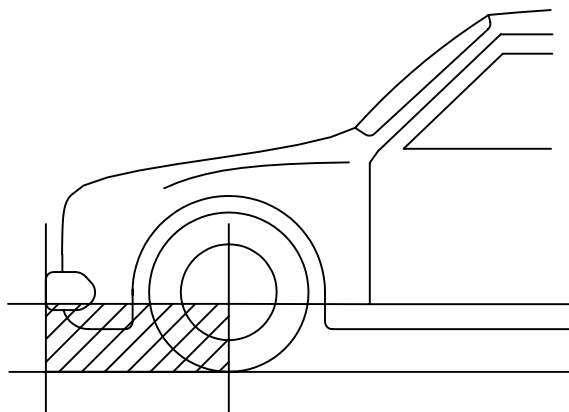

Dessin/Drawing 279-4

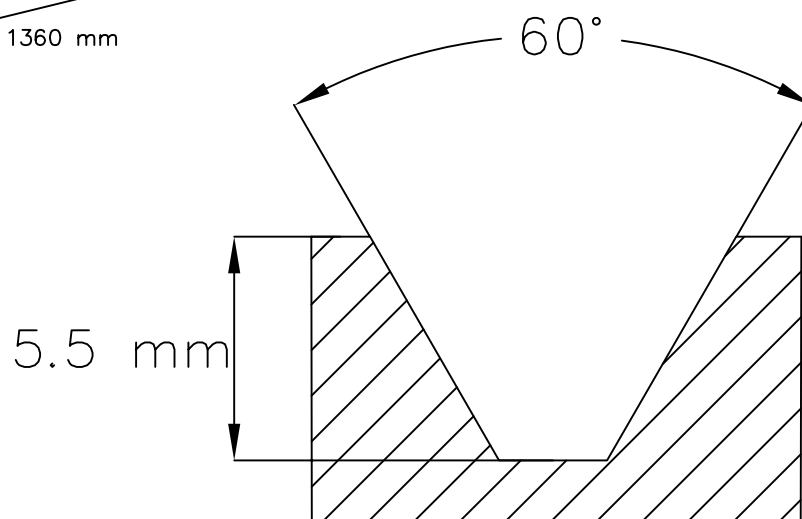

Dessin/Drawing 279-5

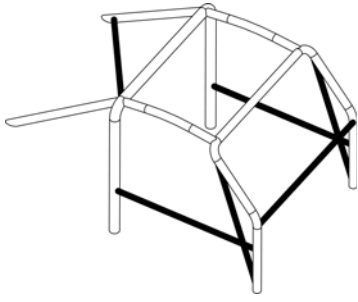

Dessin/Drawing 283-1A

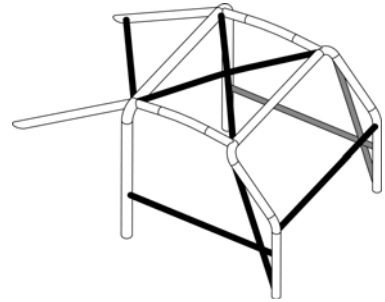

Dessin/Drawing 283-1B

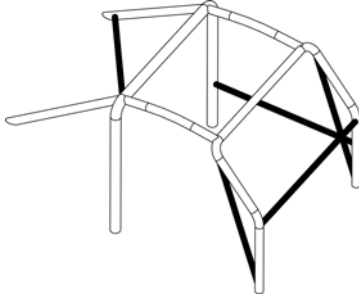

Dessin/Drawing 283-2A

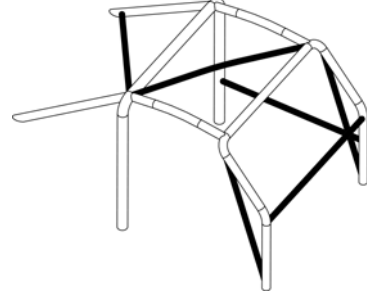

Dessin/Drawing 283-2B

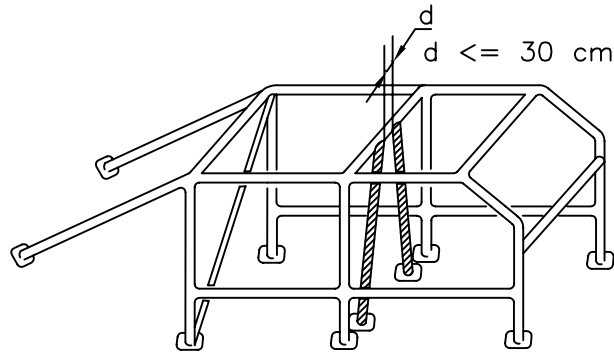

Dessin/Drawing 283-3

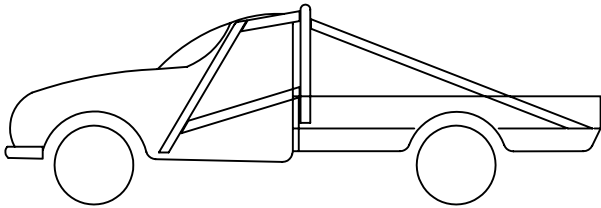

Dessin/Drawing 283-4

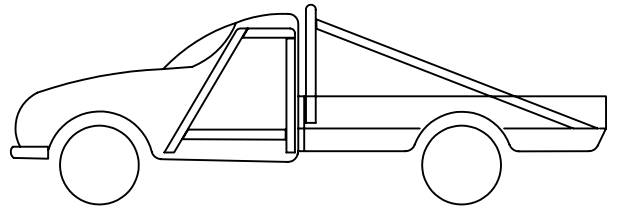

Dessin/Drawing 283-5

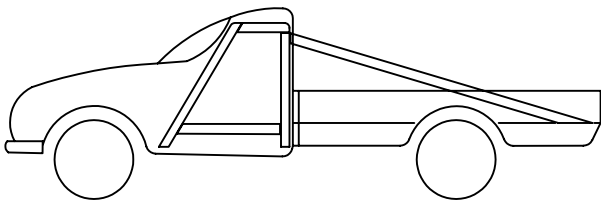

Dessin/Drawing 283-6

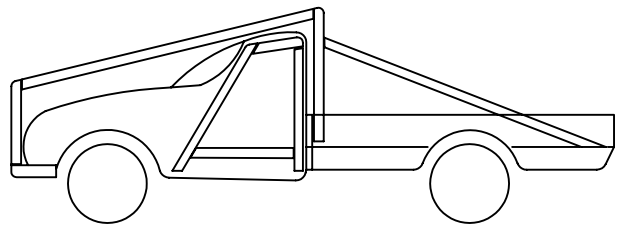

Dessin/Drawing 283-7

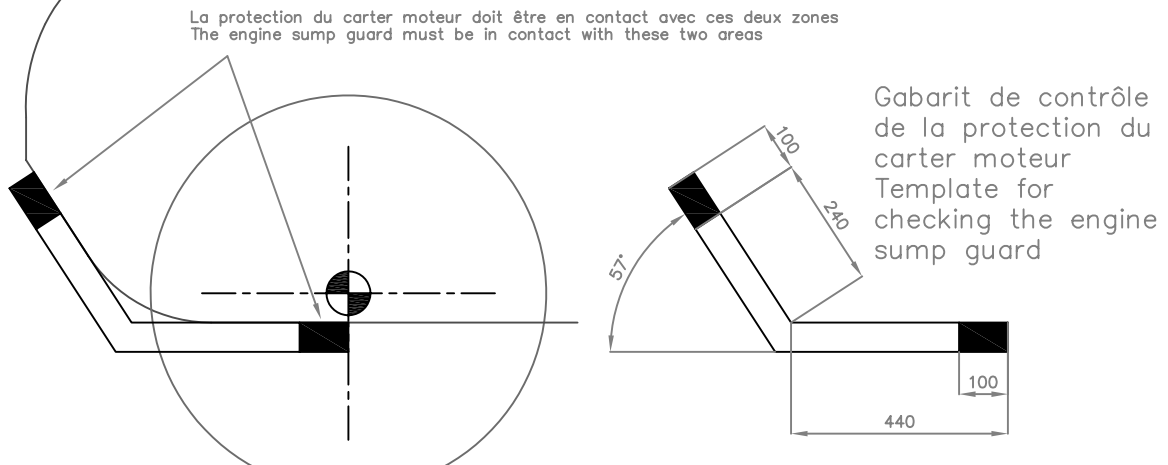
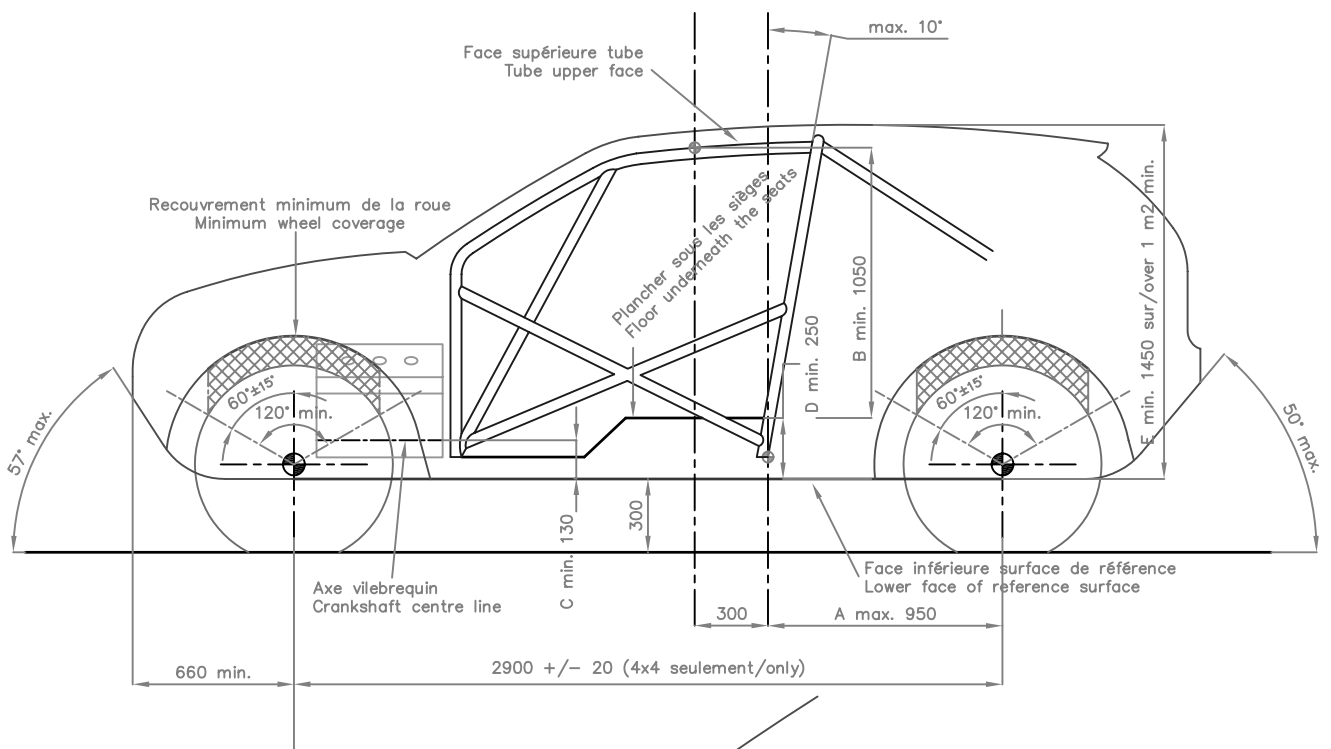
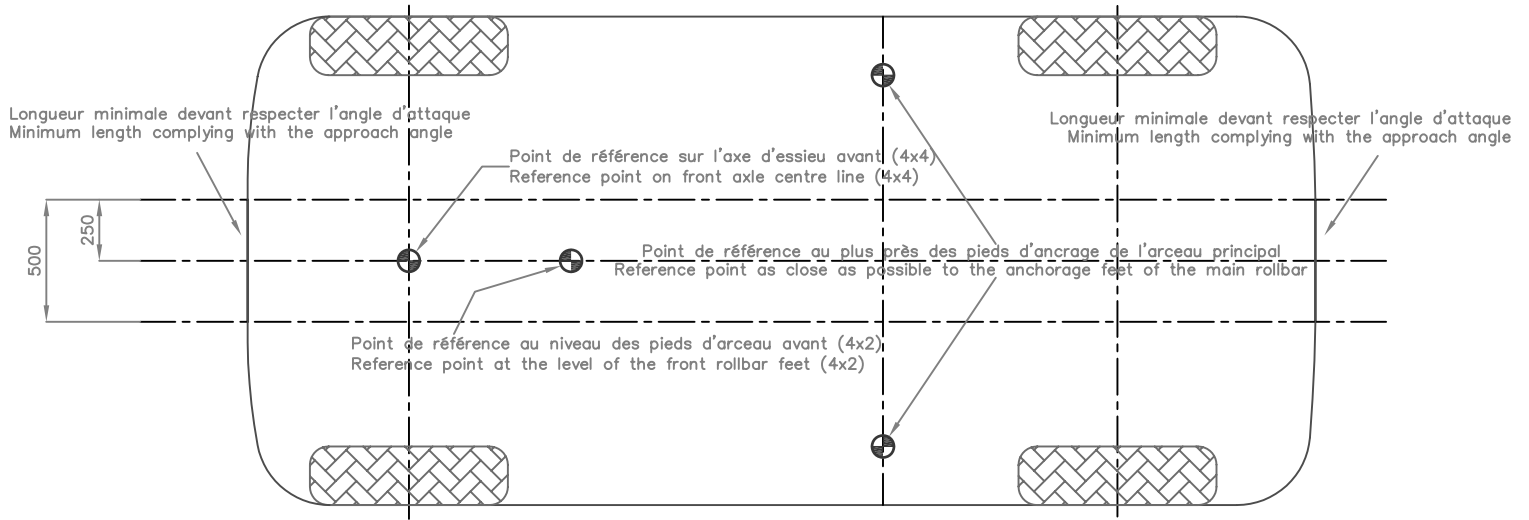

Position de l'ancrage inférieur de l'amortisseur
Position of the lower mounting point of the shock absorber

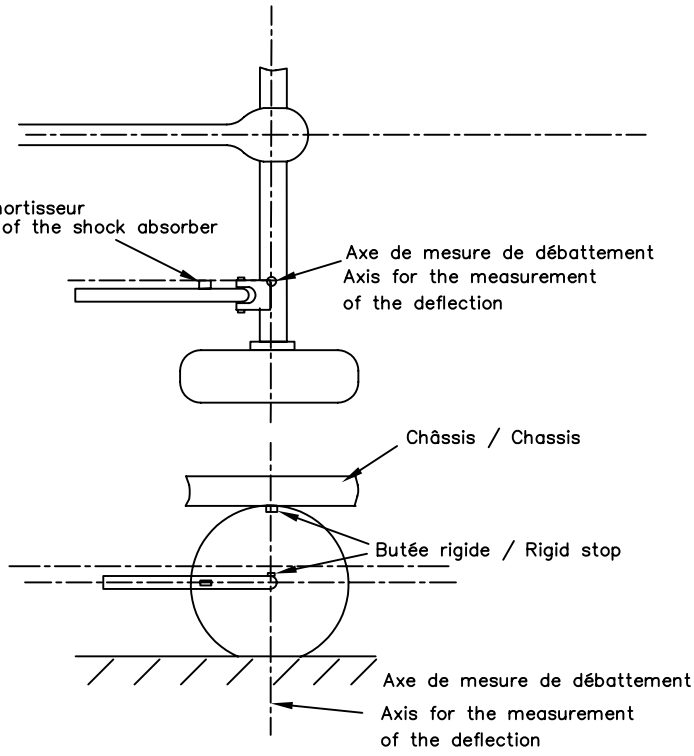

Dessin/Drawing 285-2

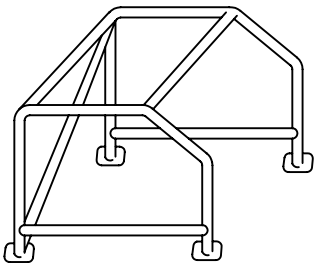

Dessin/Drawing 287-1

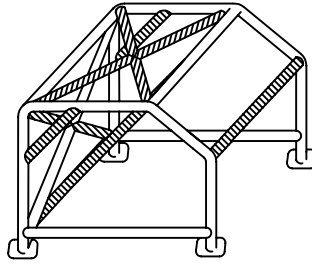

Dessin/Drawing 287-2

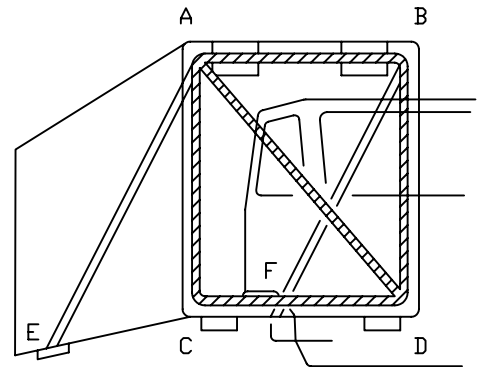

Dessin/Drawing 287-3

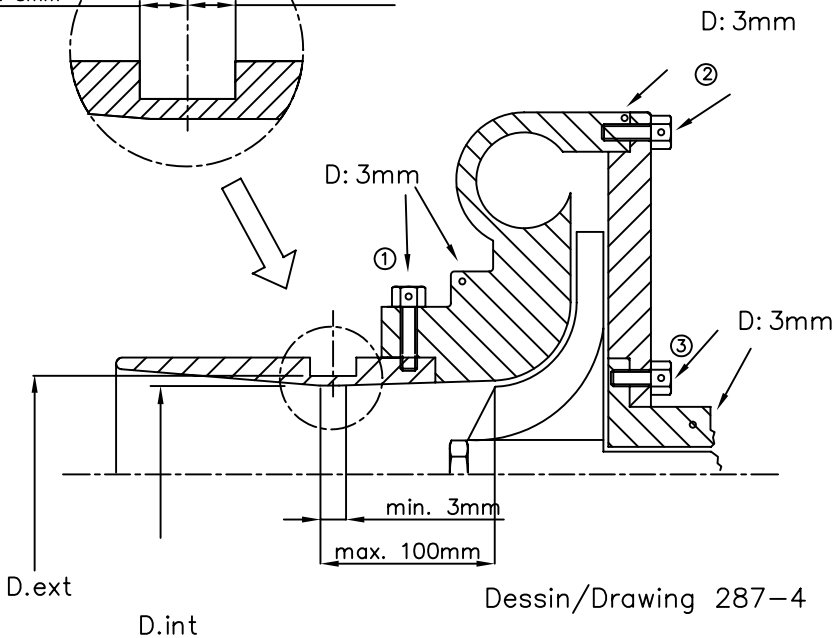
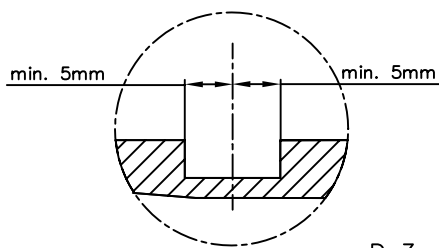

Dessin/Drawing 287-4

- ① Trou pour bride ou bride/carter de compression
Hole for restrictor or restrictor/compressor housing
- ② Trou pour carter de compression ou carter/flasque
Hole for compressor housing or housing/flange
- ③ Trou pour carter de turbine carter/flasque
Hole for turbine housing or housing/flange

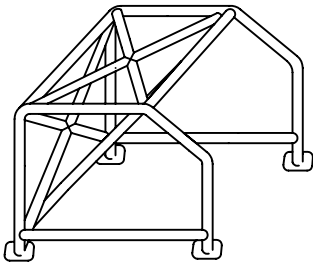

Dessin/Drawing 290-1

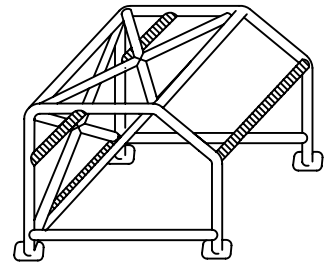

Dessin/Drawing 290-2

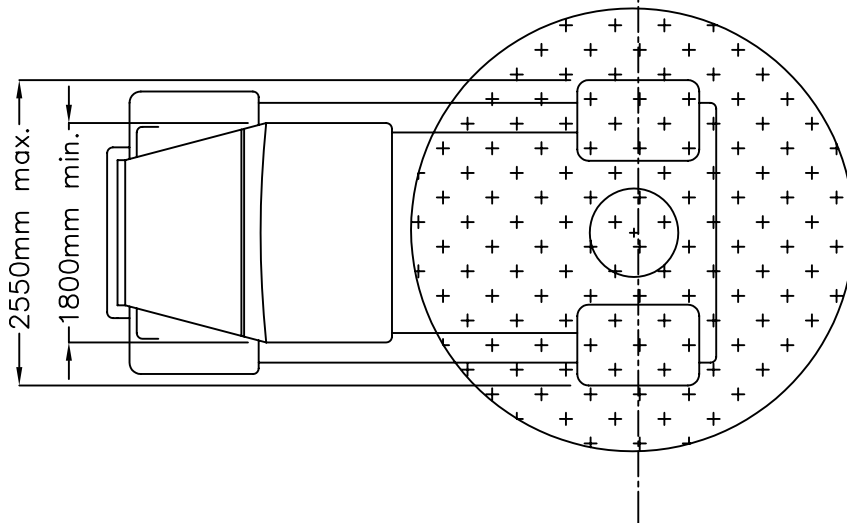
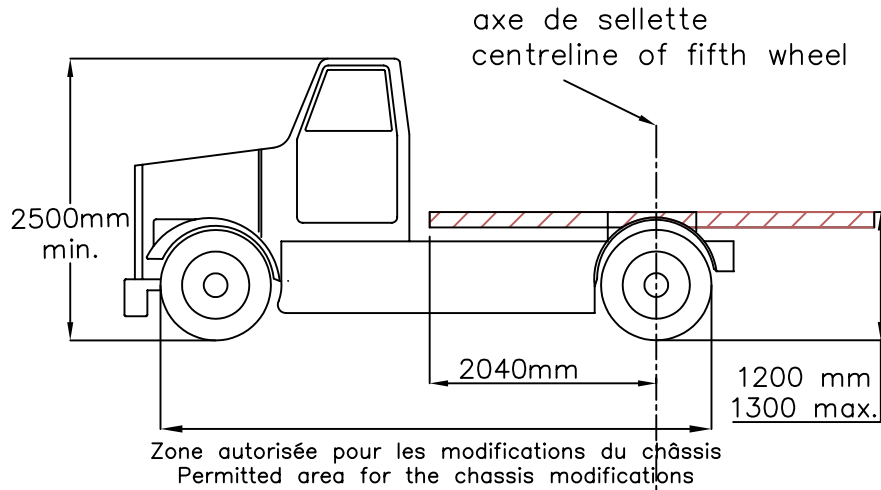

Dessin/Drawing 290-3

120mm max. à l'extérieur de la poutre principale du châssis
120mm max. from the outer surface of the chassis rail

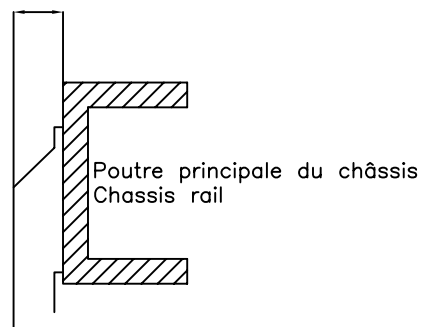

Dessin/Drawing 290-4

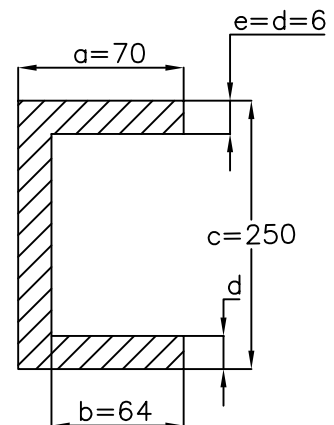

Dessin/Drawing 290-5

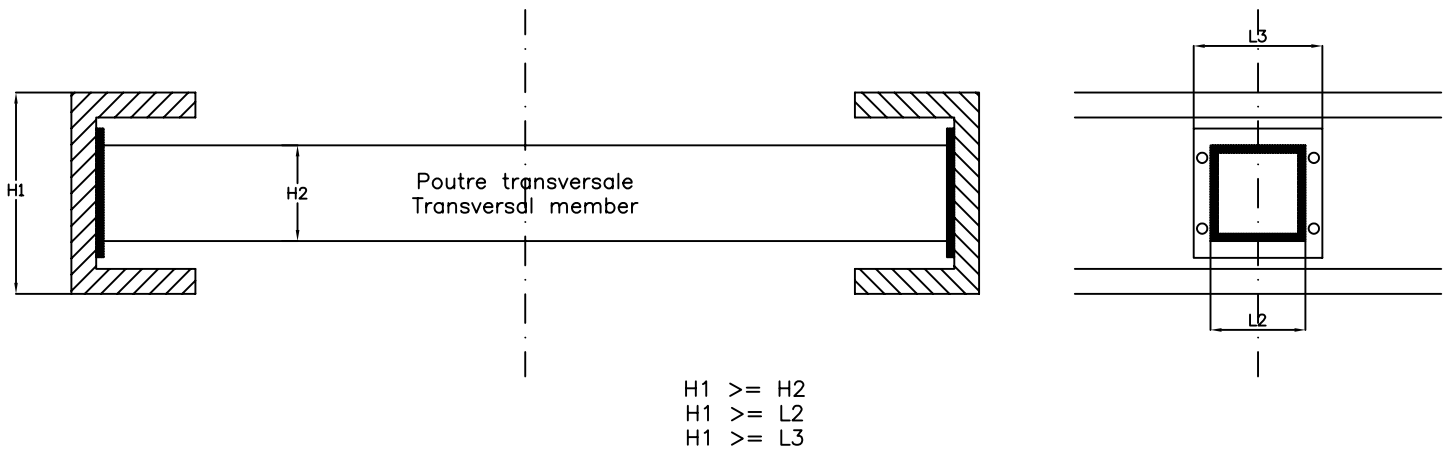

Dessin/Drawing 290-6

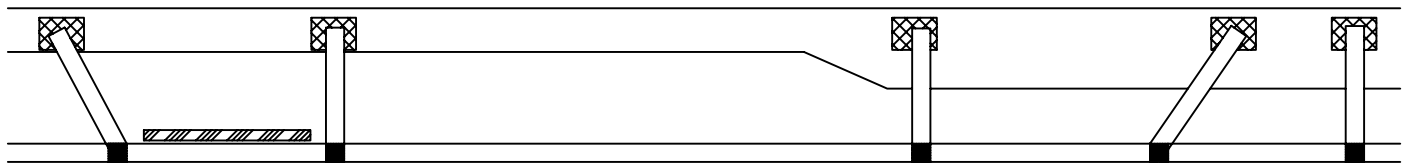
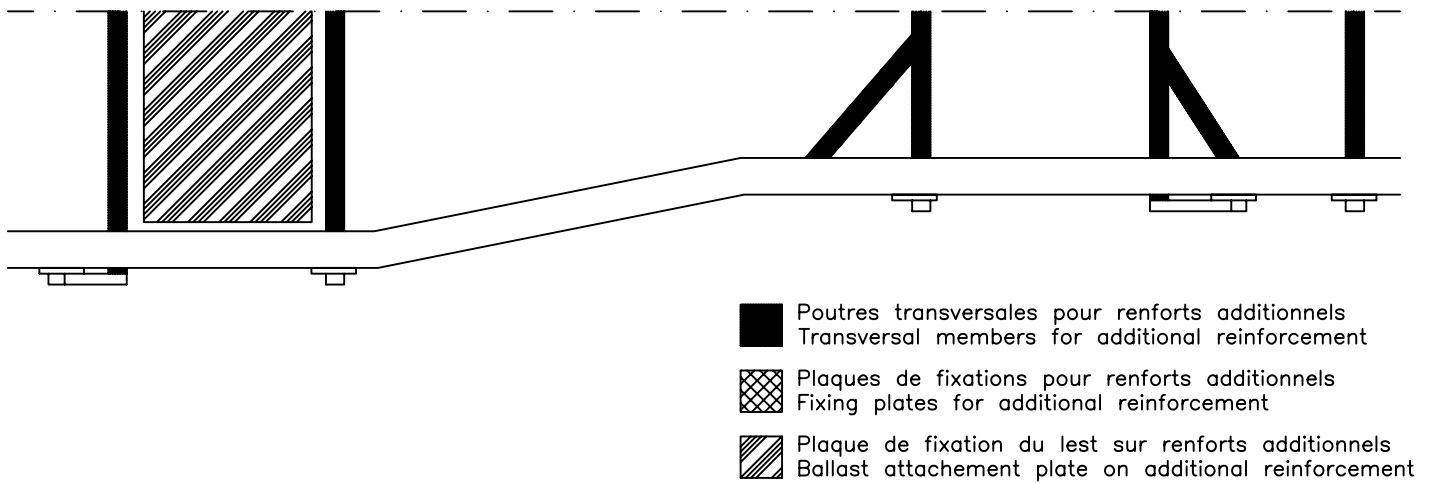

Dessin/Drawing 290-7

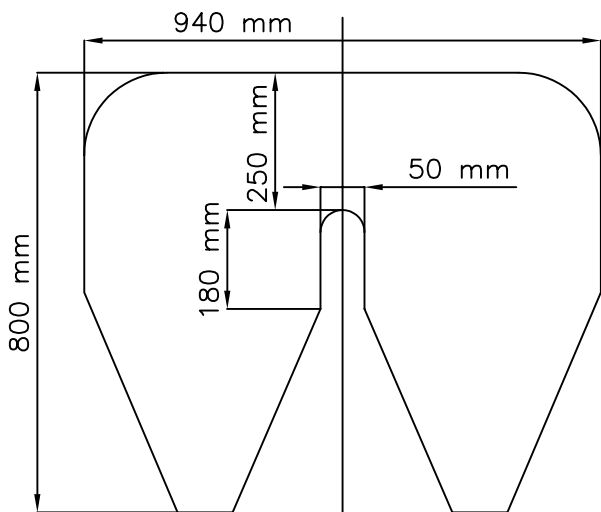

Dessin/Drawing 290-8

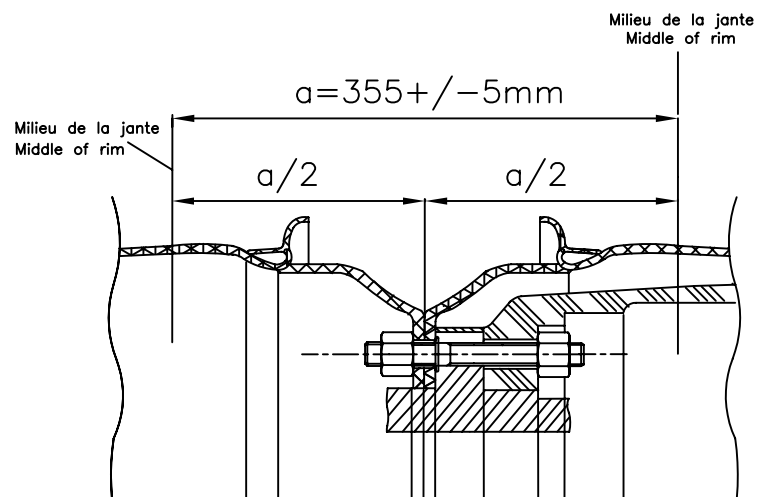

Dessin/Drawing 290-9